

Chapter 16

Stability and hydrostatic curves

1. Cross Curves of Stability

(a) GZ Cross Curves of Stability

These are a set of curves from which the righting lever about an assumed centre of gravity for any angle of heel at any particular displacement may be found by inspection. The curves are plotted for an assumed KG and, if the actual KG of the ship differs from this, a correction must be applied to the righting levers taken from the curves.

Figure 16.1 shows a set of Stability Cross Curves plotted for an imaginary ship called M.V. 'Tanker', assuming the KG to be 9 metres. A scale of displacements is shown along the bottom margin and a scale of righting levers (GZs) in metres on the left-hand margin. The GZ scale extends from +4.5 m through 0 to -1 metre. The curves are plotted at 15 degree intervals of heel between 15 degrees and 90 degrees.

To find the GZs for any particular displacement locate the displacement concerned on the bottom scale and, through this point erect a perpendicular to cut all the curves. Translate the intersections with the curves horizontally to the left-hand scale and read off the GZs for each angle of heel.

Example 1

Using the Stability Cross Curves for M.V. 'Tanker' find the GZs at 15-degree intervals between 0 degrees and 90 degrees heel when the displacement is 35 000 tonnes, and $KG = 9$ metres.

Erect a perpendicular through 35 000 tonnes on the displacement scale and read off the GZs from the left-hand scale as follows:

Angle of heel	0°	15°	30°	45°	60°	75°	90°
GZ in metres	0	0.86	2.07	2.45	1.85	0.76	-0.5

Should the KG of the ship be other than 9 metres, a correction must be applied to the GZs taken from the curves to obtain the correct GZs. The corrections are tabulated in the block at the top right-hand side of Figure 16.1

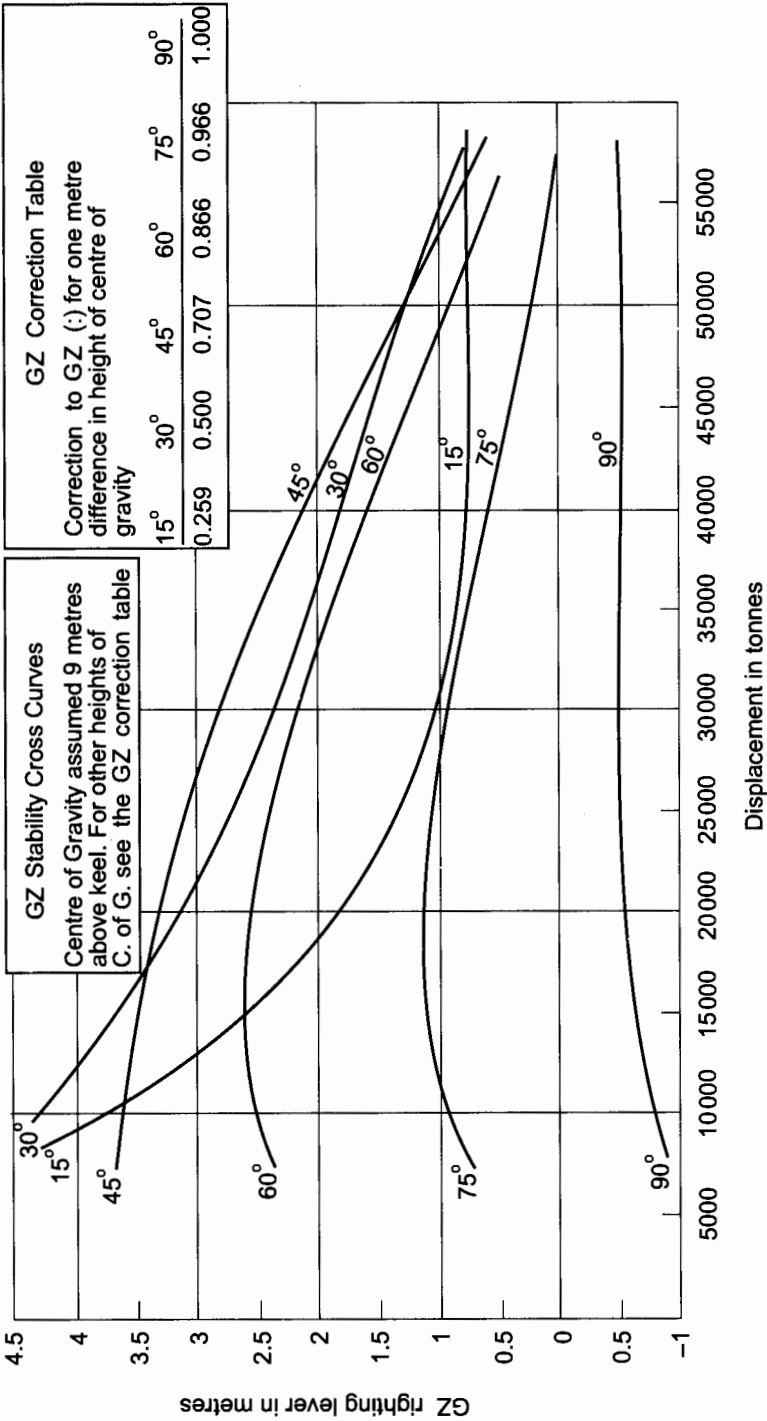

Fig. 16.1

and are given for each one metre difference between 9 metres and the ship's actual KG. To find the correction to the GZ, multiply the correction taken from the table for the angle of heel concerned, by the difference in KGs. To apply the correction: when the ship's KG is *greater* than 9 metres the ship is less stable and the correction must be *subtracted*, but when the KG is *less* than 9 metres the ship is more stable and the correction is to be *added*.

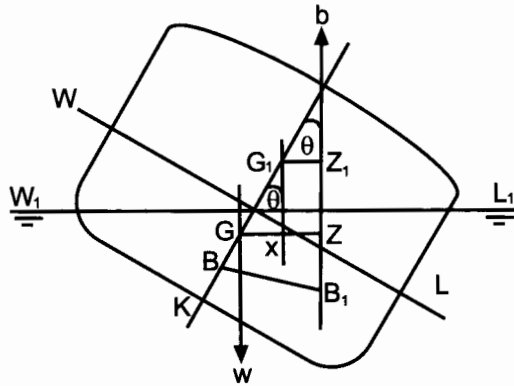

Fig. 16.2(a)

The derivation of the table is as follows:

In Figure 16.2(a), KG is 9 m, this being the KG for which this set of curves is plotted, and GZ represents the righting lever, as taken from the curves for this particular angle of heel.

Consider the case when the KG is greater than 9 m (KG_1 in Figure 16.2(a)). The righting lever is reduced to G_1Z_1 . Let G_1X be perpendicular to GZ. Then

$$\begin{aligned} G_1Z_1 &= XZ \\ &= GZ - GX \end{aligned}$$

or

$$\text{Corrected GZ} = \text{Tabulated GZ} - \text{Correction}$$

Also, in triangle GXG_1 :

$$GX = GG_1 \sin \theta^\circ$$

or

$$\text{Correction} = GG_1 \sin \theta^\circ \text{ where } \theta^\circ \text{ is the angle of heel.}$$

But GG_1 is the difference between 9 m and the ship's actual KG. Therefore, the corrections shown in the table on the Cross Curves for each one metre difference of KG are simply the Sines of the angle of heel.

Now consider the case where KG is less than 9 m (KG_2 in Figure 16.2(b)). The length of the righting lever will be increased to G_2Z_2 .

Let GY be perpendicular to G_2Z_2 then

$$G_2Z_2 = YZ_2 + G_2Y$$

Cross curves of stability (KN curves)
 $GZ = KN - KG \sin \text{Heel}$

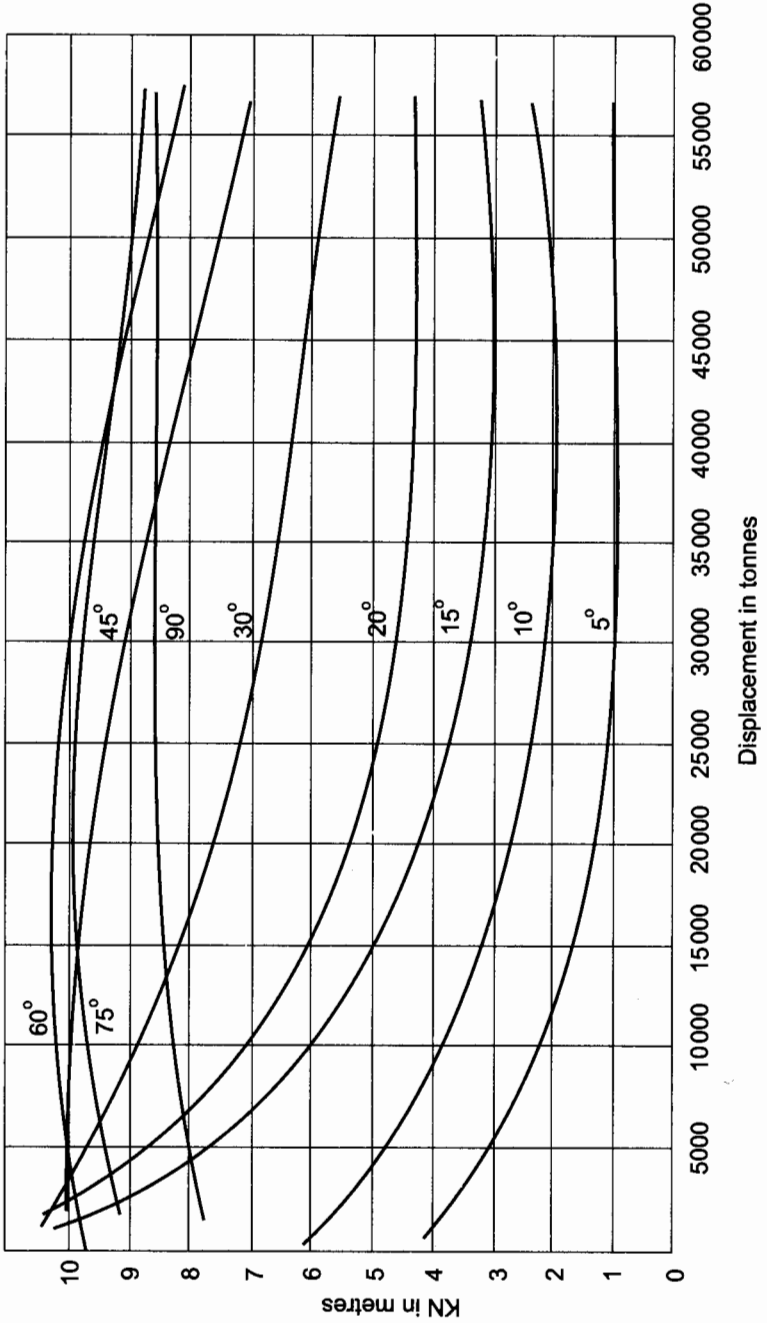

Fig. 16.3(a). M.V. 'Cargo-Carrier'

KN Cross Curves of Stability

It has already been shown that the Stability Cross Curves for a ship are constructed by plotting the righting levers for an assumed height of the centre of gravity above the keel. In some cases the curves are constructed for an assumed KG of zero. The curves are then referred to as KN curves, KN being the righting lever measured from the keel. Figure 16.3(a) shows the KN curves for an imaginary ship called the M.V. 'Cargo-Carrier'.

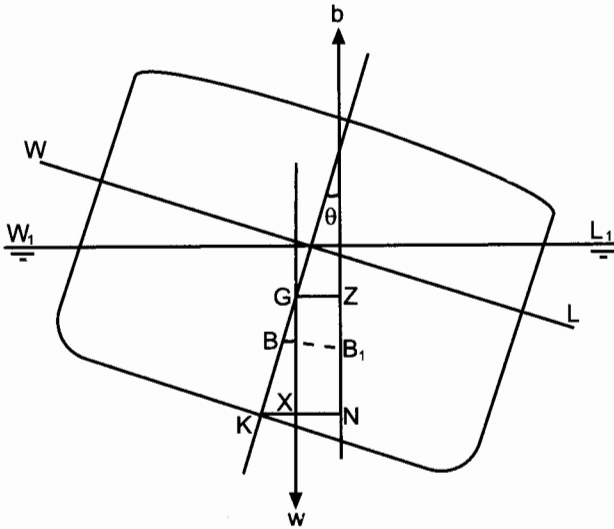

Fig. 16.3(b)

To obtain the righting levers for a particular displacement and KG the values of KN are first obtained from the curves by inspection at the displacement concerned. The correct righting levers are then obtained by subtracting from the KN values a correction equal to the product of the KG and sin Heel.

In Figure 16.3(b), let KN represent the ordinate obtained from the curves. Also, let the ship's centre of gravity be at G so that KG represents the actual height of the centre of gravity above the keel and GZ represents the length of the righting lever.

Now

$$GZ = XN$$

$$= KN - KX$$

or

$$GZ = KN - KG \sin \theta$$

Thus, the righting lever is found by *always* subtracting from the KN ordinate a correction equal to $KG \sin \text{heel}$.

Example 3

Find the righting levers for M.V. 'Cargo-Carrier' when the displacement is 40 000 tonnes and the KG is 10 metres.

Heel (θ)	KN	$\sin \theta$	KG $\sin \theta$	$GZ = KN - KG \sin \theta$
5°	0.90	0.087	0.87	0.03
10°	1.92	0.174	1.74	0.18
15°	3.11	0.259	2.59	0.52
20°	4.25	0.342	3.42	0.83
30°	6.30	0.500	5.00	1.30
45°	8.44	0.707	7.07	1.37
60°	9.39	0.866	8.66	0.73
75°	9.29	0.966	9.66	- 0.37
90°	8.50	1.000	10.00	- 1.50

2. Statical Stability curves

The curve of statical stability for a ship in any particular condition of loading is obtained by plotting the righting levers against angle of heel as shown in Figures 16.4 and 16.5.

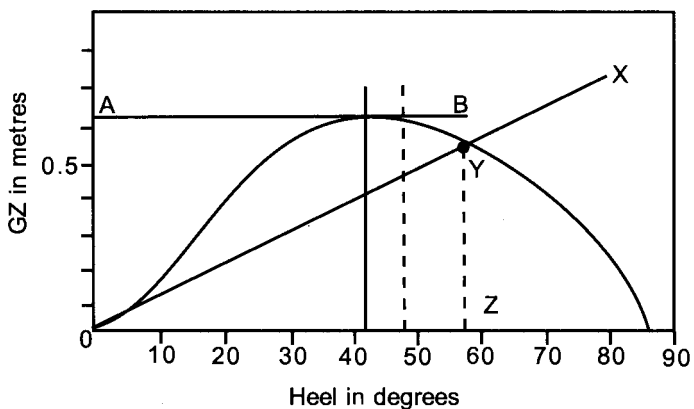

Fig. 16.4. Curve for a ship with positive initial metacentric height.

From this type of graph a considerable amount of stability information may be found by inspection:

The range of stability. This is the range over which the ship has positive righting levers. In Figure 16.4 the range is from 0 degrees to 86 degrees.

The angle of vanishing stability. This is the angle of heel at which the righting lever returns to zero, or is the angle of heel at which the sign of the

righting levers changes from positive to negative. The angle of vanishing stability in Figure 16.4 is 86 degrees.

The maximum GZ is obtained by drawing a tangent to the highest point in the curve. In Figure 16.4, AB is the tangent and this indicates a maximum GZ of 0.63 metres. If a perpendicular is dropped from the point of tangency, it cuts the heel scale at the angle of heel at which the maximum GZ occurs. In the present case the maximum GZ occurs at 42 degrees heel.

The initial metacentric height (GM) is found by drawing a tangent to the curve through the origin (OX in Figure 16.4), and then erecting a perpendicular through an angle of heel of 57.3 degrees. Let the two lines intersect at Y. Then the height of the intersection above the base (YZ), when measured on the GZ scale, will give the initial metacentric height. In the present example the GM is 0.54 metres.

Figure 16.5 shows the stability curve for a ship having a negative initial metacentric height. At angles of heel of less than 18 degrees the righting levers are negative, whilst at angles of heel between 18 degrees and 90 degrees the levers are positive. The angle of loll in this case is 18 degrees, the range of stability is 18 degrees to 90 degrees, and the angle of vanishing stability is 90 degrees. (For an explanation of angle of loll see Chapter 6, page 48.) Note how the -ve GM is plotted at 57.3°.

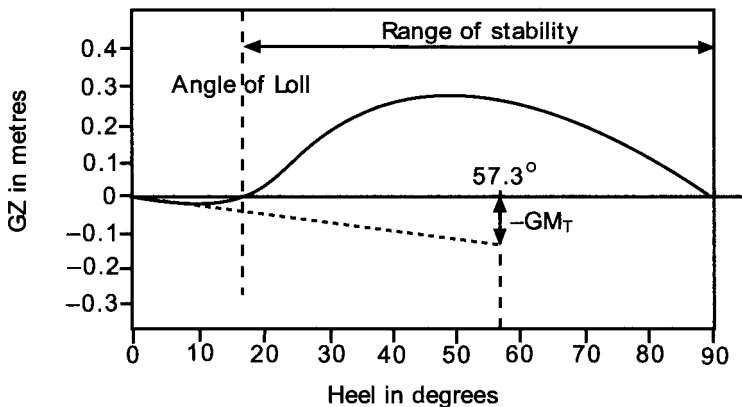

Fig. 16.5. Curve for a ship with negative initial metacentric height.

Example 1

Using the stability cross curves for M.V. 'Tanker', plot the curve of statical stability when the displacement is 33 500 tonnes and $KG = 9.3$ metres. From the curve find the following:

- The range of stability.
- The angle of vanishing stability.
- The maximum righting lever and the angle of heel at which it occurs.

Heel	Tabulated GZ (KG 9 m)	Correction to GZ ($GG_1 \sin \text{heel}$)	Required GZ (KG 9.3 m)
0°	0	$0 \times 0 = 0$	= 0
15°	0.90	$0.3 \times 0.259 = 0.08$	$0.90 - 0.08 = 0.82$
30°	2.15	$0.3 \times 0.500 = 0.15$	$2.15 - 0.15 = 2.00$
45°	2.55	$0.3 \times 0.707 = 0.21$	$2.55 - 0.21 = 2.34$
60°	1.91	$0.3 \times 0.866 = 0.26$	$1.91 - 0.26 = 1.65$
75°	0.80	$0.3 \times 0.966 = 0.29$	$0.80 - 0.29 = 0.51$
90°	- 0.50	$0.3 \times 1.000 = 0.30$	$- 0.50 - 0.30 = -0.80$

- (d) The initial metacentric height.
- (e) The moment of statical stability at 25 degrees heel.

For the graph see Figure 16.6(a),

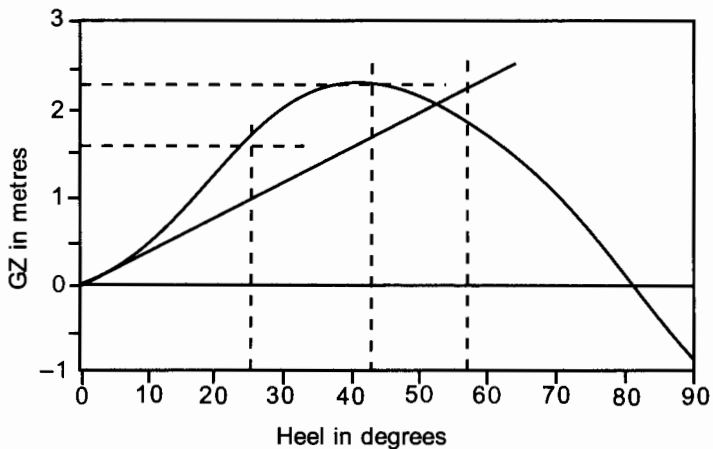

Fig. 16.6(a)

Answers from the curve:

- (a) Range of Stability 0 degrees to 81 degrees.
- (b) Angle of vanishing stability 81 degrees.
- (c) Maximum GZ = 2.35 m occurring at 43 degrees heel.
- (d) GM is 2.30 m.
- (e) GZ at 25 degrees heel = 1.64 m.

$$\text{Moment of statical stability} = W \times GZ$$

$$= 33\,500 \times 1.64$$

$$= 54\,940 \text{ tonnes m}$$

Example 2

Construct the curve of statical stability for the M.V. 'Cargo-Carrier' when the displacement is 35 000 tonnes and KG is 9 metres. From the curve you have constructed find the following:

- The range of stability,
- The angle of vanishing stability,
- The maximum righting lever and the angle of the heel at which it occurs, and
- The approximate initial metacentric height.

From the Stability Cross Curves:

Heel (θ)	KN	$\sin \theta$	KG $\sin \theta$	GZ = KN - KG $\sin \theta$
5°	0.9	0.087	0.783	0.12
10°	2.0	0.174	1.566	0.43
15°	3.2	0.259	2.331	0.87
20°	4.4	0.342	3.078	1.32
30°	6.5	0.500	4.500	2.00
45°	8.75	0.707	6.363	2.39
60°	9.7	0.866	7.794	1.91
75°	9.4	0.966	8.694	0.71
90°	8.4	1.000	9.000	-0.60

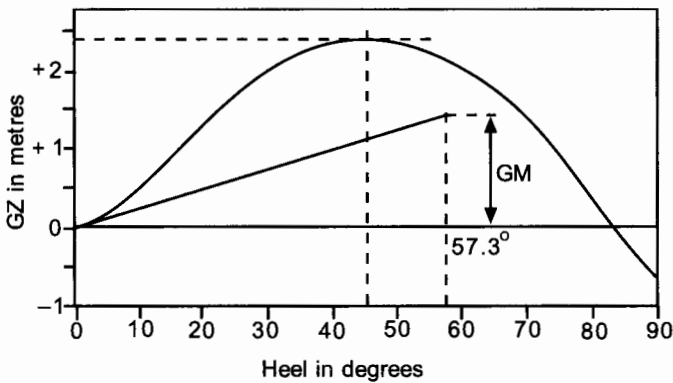

Fig. 16.6(b). This is the curve of statical stability

Answers from the curve:

- Range of stability 0° to $83\frac{3}{4}^\circ$,
- Angle of vanishing stability $83\frac{3}{4}^\circ$,
- Maximum GZ = 2.39 m occurring at 45° heel,
- Approximate GM = 1.4 m.

3. Hydrostatic curves

Hydrostatic information is usually supplied to the ship's officer in the form of a table or a graph. Figure 16.7 shows the hydrostatic curves for the imaginary ship M.V. 'Tanker'. The various items of hydrostatic information are plotted against draft.

When information is required for a specific draft, first locate the draft on the scale on the left-hand margin of the figure. Then draw a horizontal line through the draft to cut all of the curves on the figure. Next draw a perpendicular through the intersections of this line with each of the curves in turn and read off the information from the appropriate scale.

Example 1

Using the hydrostatic curves for M.V. 'Tanker', take off all of the information possible for the ship when the mean draft is 7.6 metres.

- (1) TPC = 39.3 tonnes
- (2) MCT 1 cm = 475 tonnes-metres
- (3) Displacement = 33 000 tonnes
- (4) Longitudinal centre of flotation is 2.2 m forward of amidships
- (5) Longitudinal centre of buoyancy is 4.0 m forward of amidships.

When information is required for a specific displacement, locate the displacement on the scale along the top margin of the figure and drop a perpendicular to cut the curve marked 'Displacement'. Through the intersection draw a horizontal line to cut all of the other curves and the draft scale. The various quantities can then be obtained as before.

Example 2

From the hydrostatic curves take off the information for M.V. 'Tanker' when the displacement is 37 500 tonnes.

- (1) Draft = 8.55 m
- (2) TPC = 40 tonnes
- (3) MCT 1 cm = 500 tonnes m
- (4) Longitudinal centre of flotation is 1.2 m forward of amidships.
- (5) Longitudinal centre of buoyancy is 3.7 m forward of amidships.

The curves themselves are produced from calculations involving Simpson's Rules. These involve half-ordinates, areas, moments and moments of inertia for each water line under consideration.

Using the hydrostatic curves

After the end drafts have been taken it is necessary to interpolate to find the 'mean draft'. This is the draft immediately *below the LCF* which may be aft, forward or even at amidships. This draft can be labelled d_H .

If d_H is taken as being simply the average of the two end drafts then in large full-form vessels (supertankers) and fine-form vessels (container ships) an appreciable error in the displacement can occur. (See Fig. 16.8.)

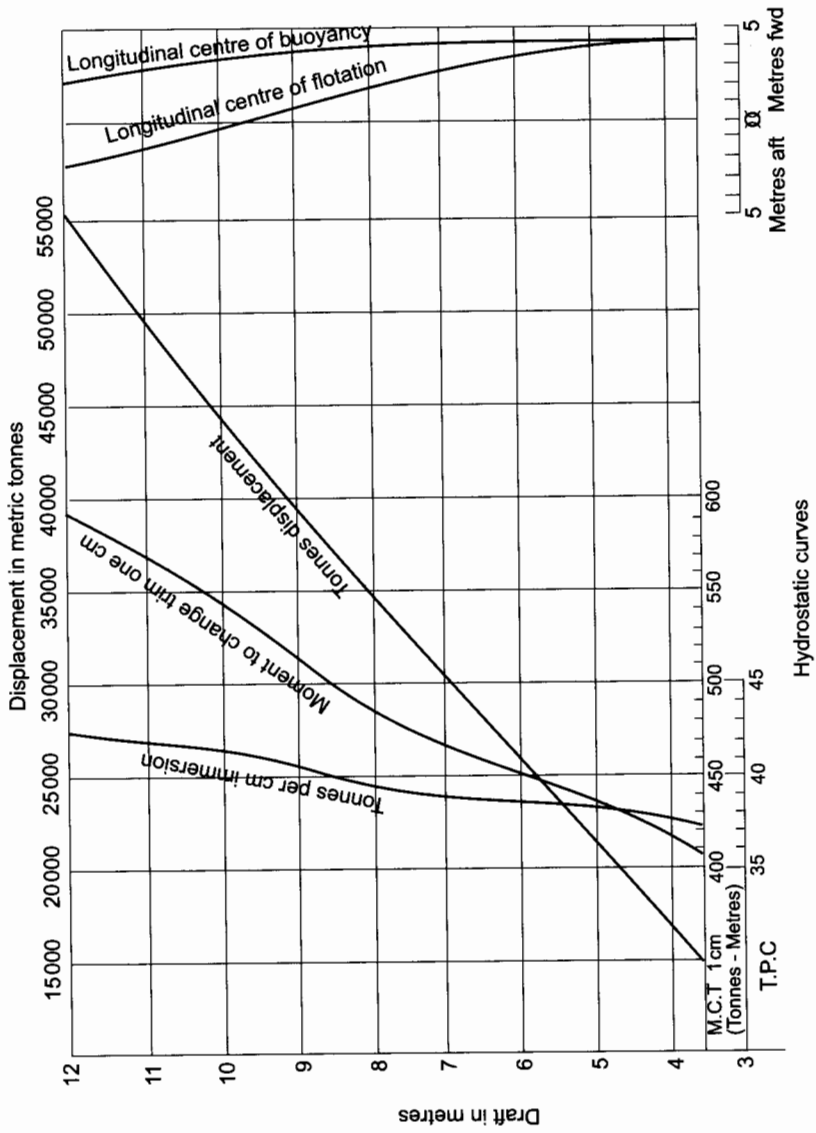

Fig. 16.7. M.V. 'Tanker'

Let us assume the true mean draft ' d_H ' is 6 m. The Naval Architect or mate on board ship draws a horizontal line parallel to the SLWL at 6 m on the vertical axis right across all of the hydrostatic curves.

At each intersection with a curve and this 6 m line, he projects downwards and reads off on the appropriate scale on the 'x' axis.

For our hydrostatic curves, at a mean draft of 6 m, for example, we would obtain the following:

$$TPC = 19.70 \text{ t}$$

$$\text{Displace}^{\text{MT}} = 10\,293 \text{ t}$$

$$\text{MCTC} = 152.5 \text{ tm/cm}$$

$$\text{LCF}_{\text{②}} = 0.05 \text{ m forward ②}$$

$$\text{LCB}_{\text{②}} = 0.80 \text{ m forward ②}$$

$$\text{KML} = 207.4 \text{ m}$$

$$\text{KM}_T = 7.46 \text{ m}$$

These values can then be used to calculate *the new end drafts and transverse stability*, if weights are *added* to the ship, *discharged* from the ship or simply *moved* longitudinally or transversely within the ship.

$\text{LCF}_{\text{②}}$ and $\text{LCB}_{\text{②}}$ are distances measured from amidships (②).

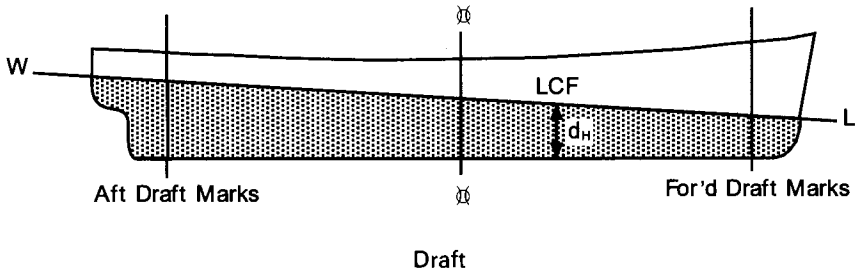

Fig. 16.8

Nowadays these values can be put on a spreadsheet in a computer package. When the hydrostatic draft d_H is keyed, the hydrostatic values appertaining to this draft are then displayed, ready for use.

A set of hydrostatic values has been calculated for a 135 m General Cargo Ship of about 10 000 tonnes deadweight. These are shown overpage. From those values a set of hydrostatic curves were drawn. These are shown in Fig. 16.9.

Hydrostatic values for Fig. 16.9 (overpage). These are for a 135 m LBP General Cargo Ship

<i>Draft d_H</i> (see below) <i>m</i>	TPC <i>tonnes</i>	KB <i>m</i>	Displace ^{MT} <i>tonnes</i>	KM _L <i>m</i>	MCTC <i>tm/cm</i>	KM _T <i>m</i>	LCF ₀ <i>m</i>	LCB ₀ <i>m</i>
9 m	20.64	4.80	16 276	146.5	167.4	7.71	2.10 aft	0.45 aft
8 m	20.36	4.27	14 253	161.8	162.9	7.54	1.20 aft	0.45 forward
7 m	20.06	3.74	12 258	181.5	158.1	7.44	0.50 aft	0.80 forward
6 m	19.70	3.21	10 293	207.4	152.5	7.46	0.05 forward	1.05 forward
5 m	19.27	2.68	8361	243.2	145.9	7.70	0.42 forward	1.25 forward
4 m	18.76	2.15	6486	296.0	138.3	8.28	0.70 forward	1.30 forward
3 m	18.12	1.61	4674	382.3	129.1	9.56	0.83 forward	1.30 forward
2½ m	17.69	1.35	3785	449.0	123.0	10.75	0.85 forward	1.30 forward

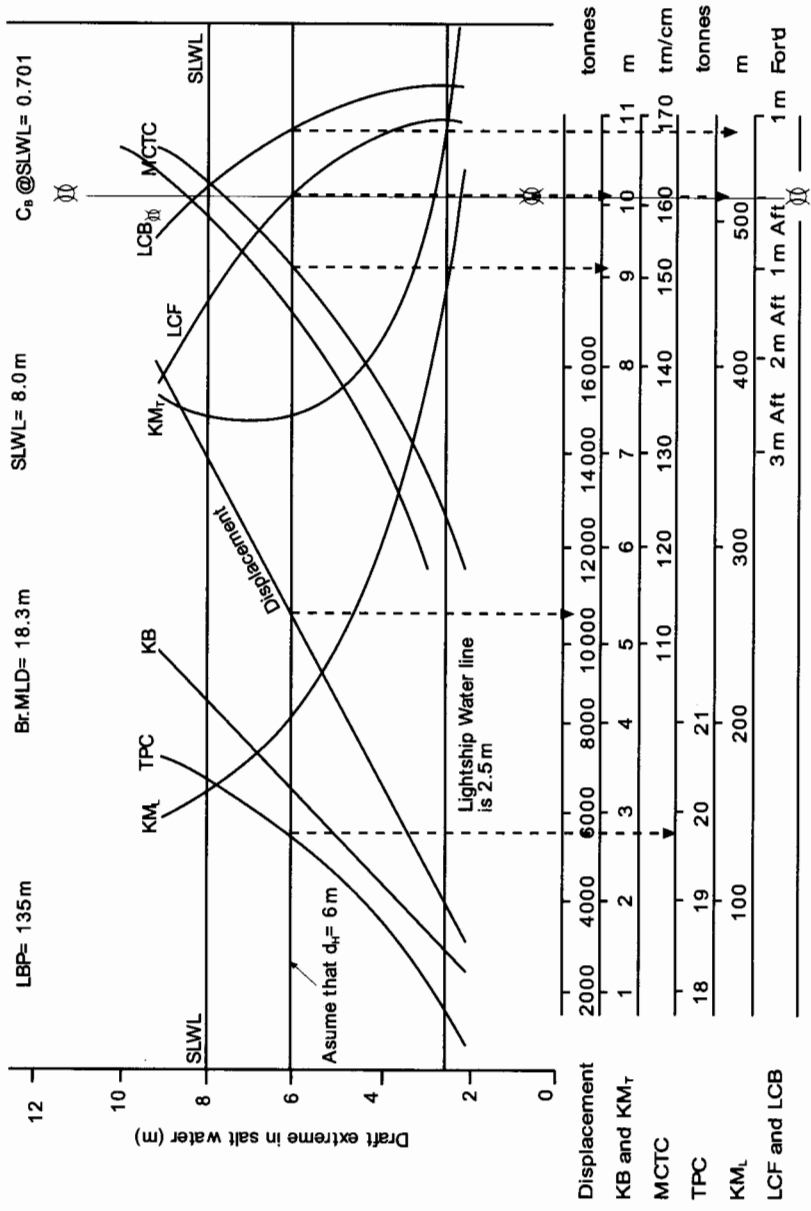

Fig. 16.9. Hydrostatic curves: based on values tabulated on previous page. These are for a 135 m LBP General Cargo Ship

EXERCISE 16

- 1 Plot the curve of stability for M.V. 'Tanker' when the displacement is 34 500 tonnes and $KG = 9$ m. From this curve find the approximate GM, the range of stability, the maximum GZ and the angle of heel at which it occurs.
- 2 Plot the curve of statical stability for M.V. 'Tanker' when the displacement is 23 400 tonnes and $KG = 9.4$ m. From this curve find the approximate GM, the maximum moment of statical stability and the angle of heel at which it occurs. Find also the range of stability.
- 3 The displacement of M.V. 'Tanker' is 24 700 tonnes and $KG = 10$ m. Construct a curve of statical stability and state what information may be derived from it. Find also the moments of statical stability at 10 degrees and 40 degrees heel.
- 4 Using the cross curves of stability for M.V. 'Tanker':
 - (a) Draw a curve of statical stability when the displacement is 35 000 tonnes, $KG = 9.2$ metres, and $KM = 11.2$ m, and
 - (b) From this curve determine the moment of statical stability at 10 degrees heel and state what other information may be obtained from the curve.
- 5 Plot the stability curve for M.V. 'Tanker' when the displacement is 46 800 tonnes and $KG = 8.5$ metres. From this curve find the approximate GM, the range of stability, the maximum GZ and the angle of heel at which it occurs.
- 6 From the hydrostatic curves for M.V. 'Tanker' find the mean draft when entering a dock where the density of the water is 1009 kg per cu. m, if the mean draft in salt water is 6.5 m.
- 7 Find the mean draft of M.V. 'Tanker' in dock water of density 1009 kg per cu. m when the displacement is 35 400 tonnes.
- 8 M.V. 'Tanker' is 200 m long and is floating at the maximum permissible draft aft. There is one more parcel of heavy cargo to load on deck to put her down to her marks at the load displacement of 51 300 tonnes. Find the position, relative to amidships, to load the parcel so as to maintain the maximum possible trim by the stern.
- 9 Using the hydrostatic curves for M.V. 'Tanker' find the displacement, MCT 1 cm and the TPC, when the ship is floating in salt water at a mean draft of 9 metres.
 Also find the new mean draft if she now enters a dock where the density of the water is 1010 kg per cu. m.
- 10 M.V. 'Tanker' is 200 m long and has a light displacement of 16 000 tonnes. She has on board 100 tonnes of cargo, 300 tonnes of bunkers, and 100 tonnes of fresh water and stores. The ship is trimmed 1.5 m by the stern. Find the new drafts if the 100 tonnes of cargo already on board is now shifted 50 m forward.
- 11 Construct the curve of statical stability for M.V. 'Cargo-Carrier' when

the displacement is 35 000 tonnes and KG is 8 metres. From this curve find

- (a) the range of stability,
 - (b) the angle of vanishing stability and,
 - (c) the maximum GZ and the heel at which it occurs.
- 12 Construct the curve of statical stability for M.V. 'Cargo-Carrier' when the displacement is 28 000 tonnes and the KG is 10 metres. From the curve find
- (a) the range of stability,
 - (b) the angle of vanishing stability, and
 - (c) the maximum GZ and the heel at which it occurs.
- 13 A vessel is loaded up ready for departure. KM is 11.9m. KG is 9.52 m with a displacement of 20 550 tonnes. From the ship's Cross Curves of Stability, the GZ ordinates for a displacement of 20 550 tonnes and a VCG of 8 m above base are as follows

Angle of heel (θ)	0	15	30	45	60	75	90
GZ ordinate (m)	0	1.10	2.22	2.60	2.21	1.25	0.36

Using this information, construct the ship's Statical Stability curve for this condition of loading and determine the following:

- (a) Maximum righting lever GZ.
 - (b) Angle of heel at which this maximum GZ occurs.
 - (c) Angle of heel at which the deck edge just becomes immersed.
 - (d) Range of stability.
- 14 Using the table of KN ordinates below calculate the righting levers for a ship when her displacement is 40 000 tonnes and her actual KG is 10 m. Draw the resulting Statical Stability curve and from it determine:
- (a) Maximum GZ value.
 - (b) Approximate GM value.
 - (c) Righting moment at the angle of heel of 25° .
 - (d) Range of Stability.

Angle of heel (θ)	0	5	10	15	20	30	45	60
KN ordinates (m)	0	0.90	1.92	3.11	4.25	6.30	8.44	9.39
Angle of heel (θ)	75	90						
KN ordinates (m)	9.29	8.50						

Chapter 17

Increase in draft due to list

1. Box-shaped vessels

The draft of a vessel is the depth of the lowest point below the waterline. When a box-shaped vessel is floating upright on an even keel as in Figure 17.1(a) the draft is the same to port as to starboard. Let the draft be 'd' and let the vessel's beam be 'b'.

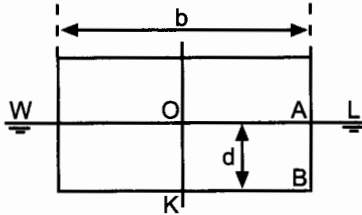

Fig. 17.1(a)

Now consider the same vessel when listed θ degrees as shown in Figure 17.1(b). The depth of the lowest point or draft is now increased to 'D' (XY).

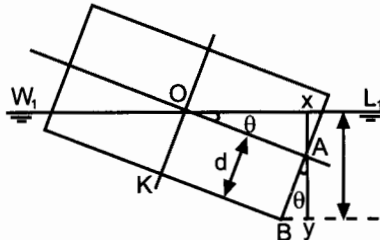

Fig. 17.1(b)

In triangle OXA:

$$OA = \frac{1}{2} b \text{ and angle } AXO = 90^\circ \quad \therefore AX = \frac{1}{2} b \sin \theta^\circ$$

In triangle ABY:

$$AB = d \text{ and angle } AYB = 90^\circ \quad \therefore AY = d \cos \theta^\circ$$

$$D = XY$$

$$= AX + AY$$

$$D = \frac{1}{2} b \sin \theta + d \cos \theta$$

or

$$\text{New draft} = \frac{1}{2} \text{ beam } \sin \text{ list} + \text{Old draft } \cos \text{ list}$$

Note. It will usually be found convenient to calculate the draft when listed by using the triangles AOX and ABY.

Example 1

A box-shaped ship with 12 m beam is floating upright at a draft of 6.7 m. Find the increase in draft if the vessel is now listed 18 degrees.

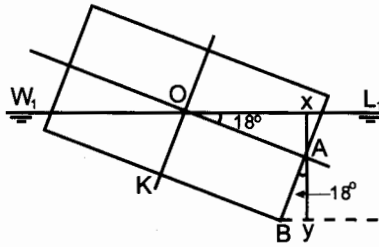

Fig. 17.2(a)

In triangle OAX:

$$\text{Angle } AOX = 18^\circ$$

Therefore use course 18°

$$OA \text{ (Dist.)} = 6.0 \text{ m}$$

$$AX \text{ (Dep.)} = 1.85 \text{ m}$$

In triangle ABY:

$$\text{Angle } BAY = 18^\circ$$

Therefore use course 18°

$$AB \text{ (Dist.)} = 6.7 \text{ m}$$

$$AY \text{ (D. Lat.)} = 6.37 \text{ m}$$

$$\begin{array}{rcl}
 AX & = & 1.85 \text{ m} \\
 AY & = & +6.37 \text{ m} \\
 \text{New draft} & = & \underline{8.22 \text{ m}} \\
 \text{Old draft} & = & \underline{+6.70 \text{ m}} \\
 & & 1.52 \text{ m}
 \end{array}$$

Ans. Increase = 1.52 m

Example 2

Using the dimensions of the ship given in example 1, proceed to calculate the increase in draft at 3° intervals from 0° to 18° . Plot a graph of draft increase $\propto \theta$.

$$\frac{1}{2} \text{ beam } \sin \theta = \frac{1}{2} \times 12 \times \sin \theta = 6 \sin \theta \quad (\text{I})$$

$$\text{Old draft } \cos \theta = 6.7 \cos \theta \quad (\text{II})$$

Increase in draft = (I) + (II) - Old draft in metres.

Angle of list	$6 \sin \theta$	$6.7 \cos \theta$	Old draft	Increase in draft (m)
0°	0	6.70	6.70	0
3°	0.31	6.69	6.70	0.30
6°	0.63	6.66	6.70	0.59
9°	0.94	6.62	6.70	0.86
12°	1.25	6.55	6.70	1.10
15°	1.55	6.47	6.70	1.32
18°	1.85	6.37	6.70	1.52

The above results clearly show the increase in draft or loss of underkeel clearance when a vessel lists.

Ships in the late 1990s are being designed with shorter lengths and wider breadths mainly to reduce first cost and hogging/sagging characteristics.

These wider ships are creating problems sometimes when initial underkeel clearance is only 10 per cent of the ship's static draft. It only requires a small angle of list for them to go aground in way of the bilge strakes.

One ship, for example, is the supertanker *Esso Japan*. She has an LBP of 350 m and a width of 70 m at amidships. Consequently extra care is required should possibilities of list occur.

Figure 17.2(b) (on page 182) shows the requested graph of draft increase $\propto \theta$.

2. Vessels having a rise of floor

Example 3

A ship has 20 m beam at the waterline and is floating upright at 6 m draft. If the rise of floor is 0.25 m, calculate the new draft if the ship is now listed 15 degrees (See Figure 17.3)

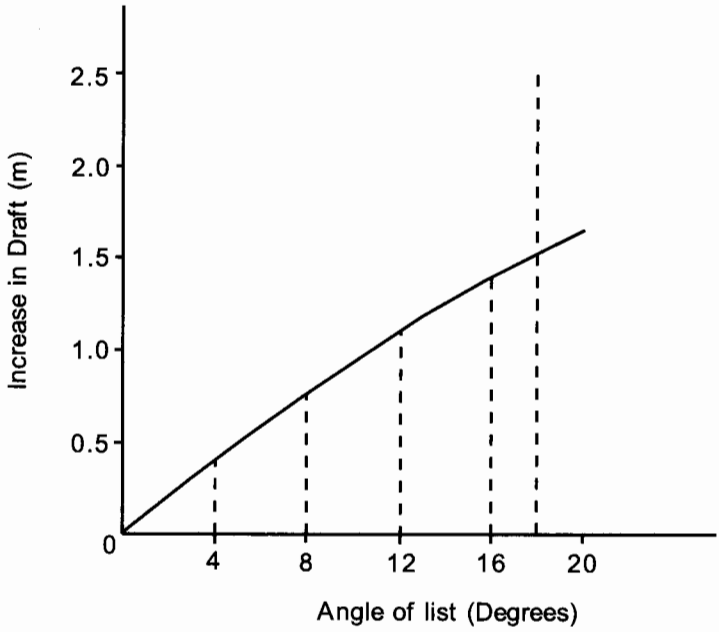

Fig. 17.2(b). Draft increase \propto angle of list θ

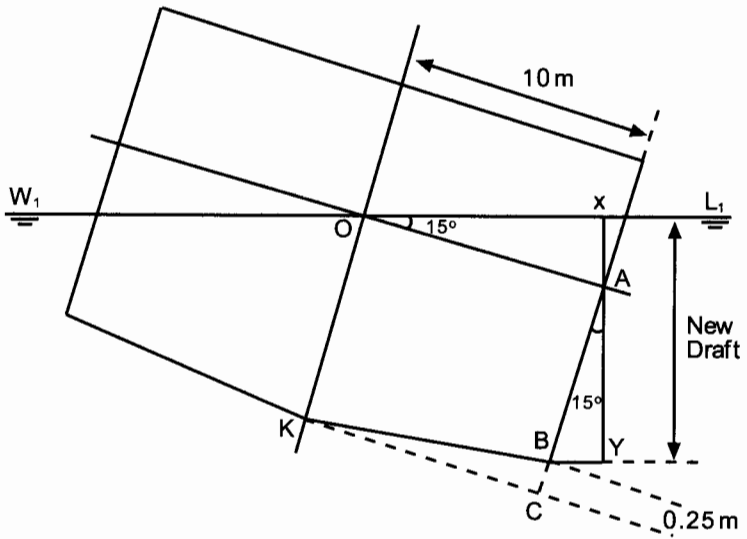

Fig. 17.3

In triangle OAX:

$$\text{Angle O} = 15^\circ$$

Therefore use course 15°

$$\text{AO (Dist.)} = 10 \text{ m}$$

$$\text{AX (Dep.)} = 2.59 \text{ m}$$

In triangle ABY:

$$\text{Angle A} = 15^\circ$$

Therefore use course 15°

$$\begin{aligned} \text{AB (Dist.)} &= \text{AC} - \text{BC} \\ &= \text{Old draft} - \text{Rise of floor} \\ &= 6 \text{ m} - 0.25 \text{ m} \end{aligned}$$

$$\text{AB (Dist.)} = 5.75 \text{ m}$$

$$\text{AY (D. Lat.)} = 5.55 \text{ m}$$

$$\text{AX} = 2.59 \text{ m}$$

$$\text{AY} = \underline{+5.55 \text{ m}}$$

$$\text{XY} = 8.14 \text{ m}$$

Ans. New draft = 8.14 metres

If the formula is to be used to find the new draft it must now be amended to allow for the rise of floor as follows:

$$\text{New draft} = \frac{1}{2} \text{ beam} \sin \text{list} + (\text{Old draft} - \text{Rise}) \cos \text{list.}$$

Note. In practise, the shipbuilder's naval architect usually calculates the increase in draft for the ship at various angles of list and supplies the information to the ship's officer by means of a table on the plans of the ship.

The rise of floor, similar to tumblehome on merchant ships, has almost become obsolete on merchant ships of today.

Exercise 17

- 1 A box-shaped vessel with 10 m beam, and 7.5 m deep, floats upright at a draft of 3 m. Find the increase of draft when listed 15 degrees to starboard.
- 2 A ship 90 m long, 15 m beam at the waterline, is floating upright at a draft of 6 m. Find the increase of draft when the ship is listed 10 degrees, allowing 0.15 m rise of floor.
- 3 A box-shaped vessel $60 \text{ m} \times 6 \text{ m} \times 4 \text{ m}$ draft is floating upright. Find the increase in the draft if the vessel is now listed 15 degrees to port.
- 4 A box-shaped vessel increases her draft by 0.61 m when listed 12 degrees to starboard. Find the vessel's beam if the draft, when upright, was 5.5 m.
- 5 A box-shaped vessel with 10 m beam is listed 10 degrees to starboard and the maximum draft is 5 m. A weight already on board is shifted transversely across the deck, causing the vessel to list to port. If the final list is 5 degrees to port, find the new draft.