

Chapter 21

Ground Tackle

Ground tackle consists of all the equipment used in anchoring. This includes the anchors, anchor cables or chain, connecting devices, and the anchor windlass. This chapter discusses these items and their nomenclature, maintenance, and use.

ANCHORS

21-1. An anchor works like a pickaxe. When the pick is driven into the ground, it takes a great deal of force to pull it loose with a straight pull on the handle. However, by lifting the handle, a leverage is obtained which breaks it free. In the same way, the anchor holds because the anchor chain or cable causes the pull on the anchor to be in line with its shank. When it is desired to break the anchor free, the chain is taken in and this lifts the shank of the anchor and gives the leverage needed to loosen the anchor's hold. The primary function of an anchor is to hold the ship against the current and wind. On landing craft, stern anchors are also used to prevent broaching on the beach and to assist in retracting from the beach.

NOMENCLATURE

21-2. The following describes the different parts of an anchor (see also Figure 21-1, page 21-2).

- **Ring (Shackle).** Device used to shackle the anchor chain to the shank of the anchor. The ring is secured to the top of the shank with a riveted pin.
- **Shank.** The long center part of the anchor running between the ring and the crown.
- **Crown.** The rounded lower section of the anchor to which the shank is secured. The shank is fitted to the crown with a pivot or ball-and-socket joint that allows a movement from 30° to 45° either way.
- **Arms.** The parts that extend from each side of the crown.
- **Throat.** The inner curved part of an arm where it joins the shank.
- **Fluke or palm.** The broad shield part of the anchor that extends upward from the arms.
- **Blade.** That part of the arm extending outward below the fluke.
- **Bill or pea.** Tip of the palm or fluke.

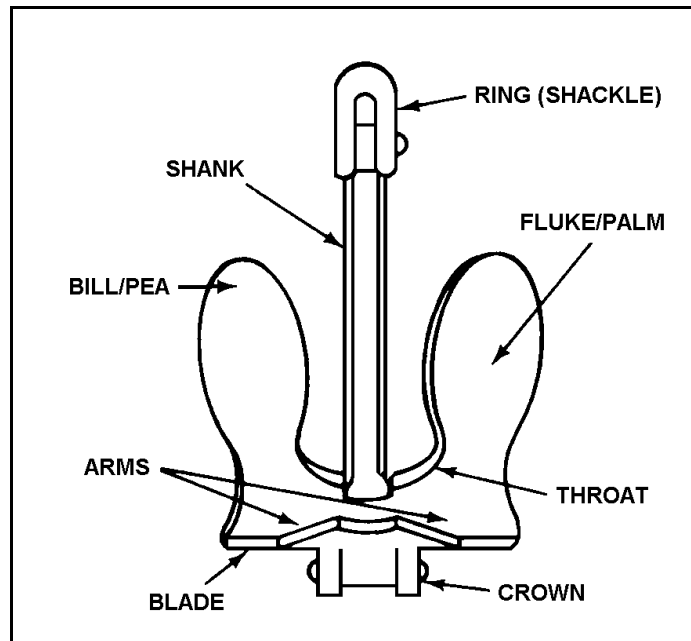

Figure 21-1. Nomenclature of an Anchor

TYPES

21-3. Three types of anchors used aboard Army vessels are the stockless, the lightweight, and the mushroom (see Figure 21-2).

Note: All vessels, 380 tons and over, must carry a spare bow anchor. Seagoing tugs must carry a kedge anchor.

ANCHOR CHAIN

21-4. Modern anchor chain is made of die-lock chain with studs. The size of the link is designated by its diameter, called wire diameter. The Federal Supply Catalog lists standard sizes from 3/4 inch to 4 3/4 inches. Wire diameter is measured at the end and a little above the centerline of the link. The length of a standard link is 6 times its diameter and width is 3.6 times its diameter. All links are studded; that is, a solid piece is forged in the center of the link. Studs prevent the chain from kinking and the links from pounding on adjacent links. They also further strengthen the chain up to 15 percent.

CHAIN NOMENCLATURE

21-5. A chain is made up of many parts besides links. A variety of equipment is required to use and maintain the chain.

Standard Shots

21-6. The lengths of chain that are connected to make up the ship's anchor chains are called shots. A standard shot is 15 fathoms (90 feet) long.

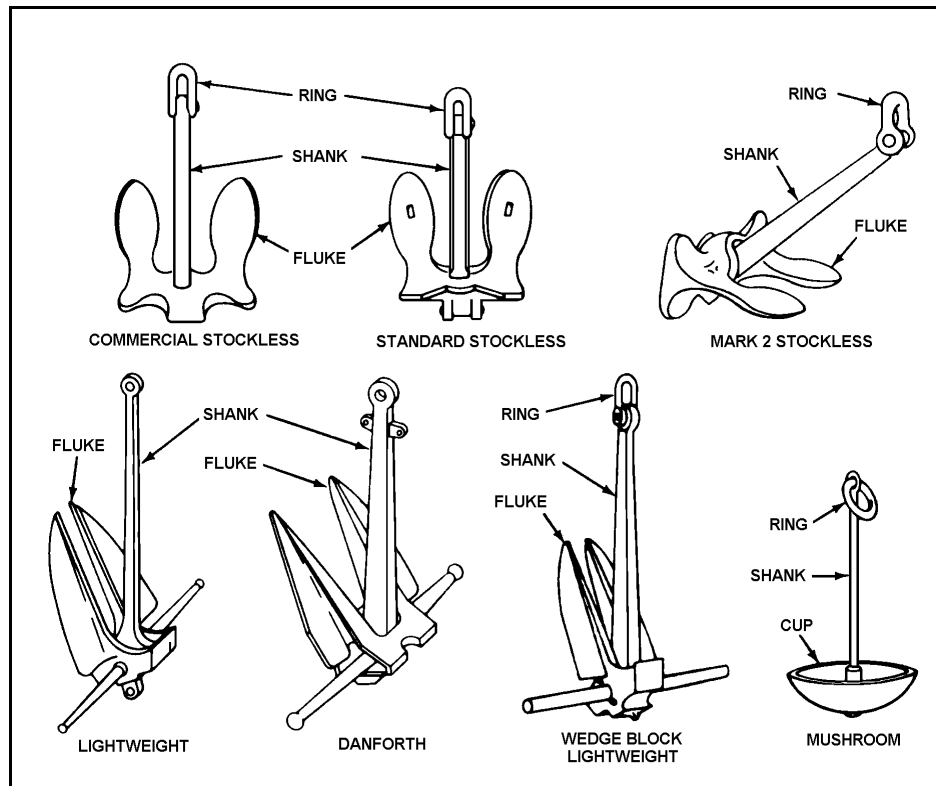

Figure 21-2. Types of Anchors

Detachable Links

21-7. Shots of anchor chain are joined by a detachable link. The detachable link (see Figure 21-3, page 21-4) consists of a C-shape link with two coupling plates which form one side and stud of the link. A taper pin holds the parts together and is locked in place at the large end by a lead plug. Detachable link parts are not interchangeable. Therefore, matching numbers are stamped on the C-link and on each coupling plate to ensure identification and proper assembly. You will save time and trouble when trying to match these parts if you disassemble only one link at a time and clean, slush, and reassemble it before disassembling another. When reassembling a detachable link, make sure the taper pin is seated securely. This is done by driving it in with a punch and hammer before inserting the lead plug over the large end of the pin. Detachable link toolbox sets contain tools, including spare taper pins and lock plugs, for assembling and disassembling links and detachable end links.

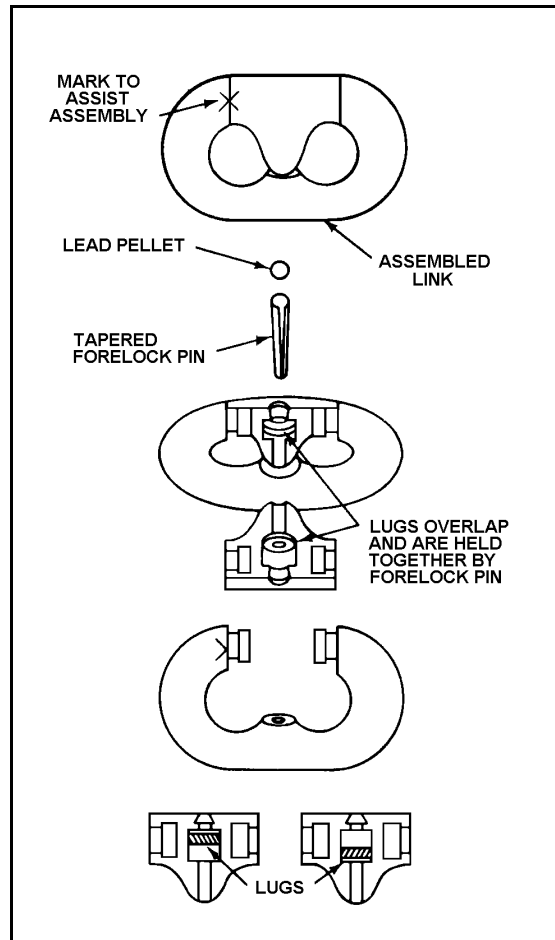

Figure 21-3. Detachable Link

Bending Shackles

21-8. Bending shackles are used to attach the anchor to the chain.

Note: The slush, a preservative and lubricant, is a mixture of 40 percent white lead and 60 percent tallow by volume. If the white lead/tallow mixture is not available, grease (MIL-G-23549A) may be substituted.

Chain Swivels

21-9. Furnished as part of the outboard swivel shot, chain swivels reduce kinking or twisting of the anchor chain.

Outboard Swivel Shots

21-10. Standard outboard swivel shots consist of detachable links, swivel, end link, and bending shackle. They are used on most vessels to attach the anchor chain to the anchor. These shots vary in length up to approximately 6 1/2 fathoms and are also termed bending shots. The taper pin in the detachable link, located in the outboard swivel shot, is additionally secured with a wire-locking clip.

MAKEUP OF AN ANCHOR CABLE

21-11. An anchor cable is an assembly of a number of individual units properly secured together (see Figure 21-4). These units are connected to the anchor by means of a swivel piece made up of shackles, swivels, and special links.

Note: Each shot of chain is joined together with a detachable link.

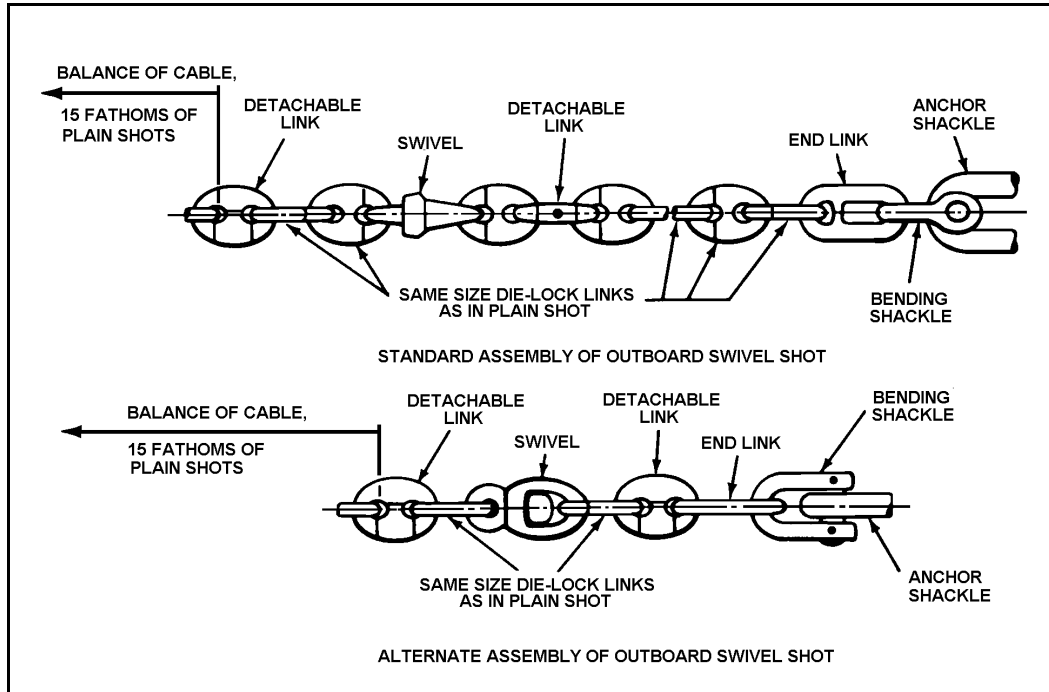

Figure 21-4. Connecting Anchor to Anchor Cable

MARKING THE ANCHOR CHAIN

21-12. For the safety of every ship, the ship's officers and the boatswain must know at all times the scope or how much anchor chain has been paid out. To make this information quickly available, a system of chain markings is used. Figure 21-5 shows the standard system for marking an anchor chain.

COLOR MARKINGS

21-13. The tools required for color marking an anchor chain are wire brush, paint brush, rags, and paint (red, white, blue, and yellow enamel paint).

- **15 fathoms (1 shot).** The detachable link IS painted red, and one link on each side is painted white.
- **30 fathoms (2 shots).** The detachable link is painted white, and two links on each side are painted white.
- **45 fathoms (3 shots).** The detachable link is painted blue, and three links on each side are painted white.
- **60 fathoms (4 shots).** The detachable link is painted red, and four links on each side are painted white.
- **75 fathoms (5 shots).** The detachable link is painted white, and five links on each side are painted white.

Paint each link in the next to last shot yellow. The yellow alerts you that you are running out of chain. Paint each link in the last shot red.

Note: 1 fathom = 6 feet. There are 15 fathoms (90 feet) in a shot of anchor chain.

Note: This method is used through the entire marking procedure alternating red, white, and blue for detachable links as appropriate.

WIRE MARKINGS

21-14. In addition to color markings, wire markings may also be used. The purpose of the wire marking is to let you count the shots by feel during blackout conditions or if the markings on the chain are worn off or rusted over.

- **1st shot.** One turn of wire on the first stud from each side of the detachable link.
- **2d shot.** Two turns of wire on the second stud from each side of the detachable link.

- **3d shot.** Three turns of wire on the third stud from each side of the detachable link.
- **4th shot.** Four turns of wire on the fourth stud on each side of the detachable link.

- **5th shot.** Five turns of wire on the fifth stud on each side of the detachable link.
- **6th shot.** Six turns of wire on the sixth stud on each side of the detachable link.

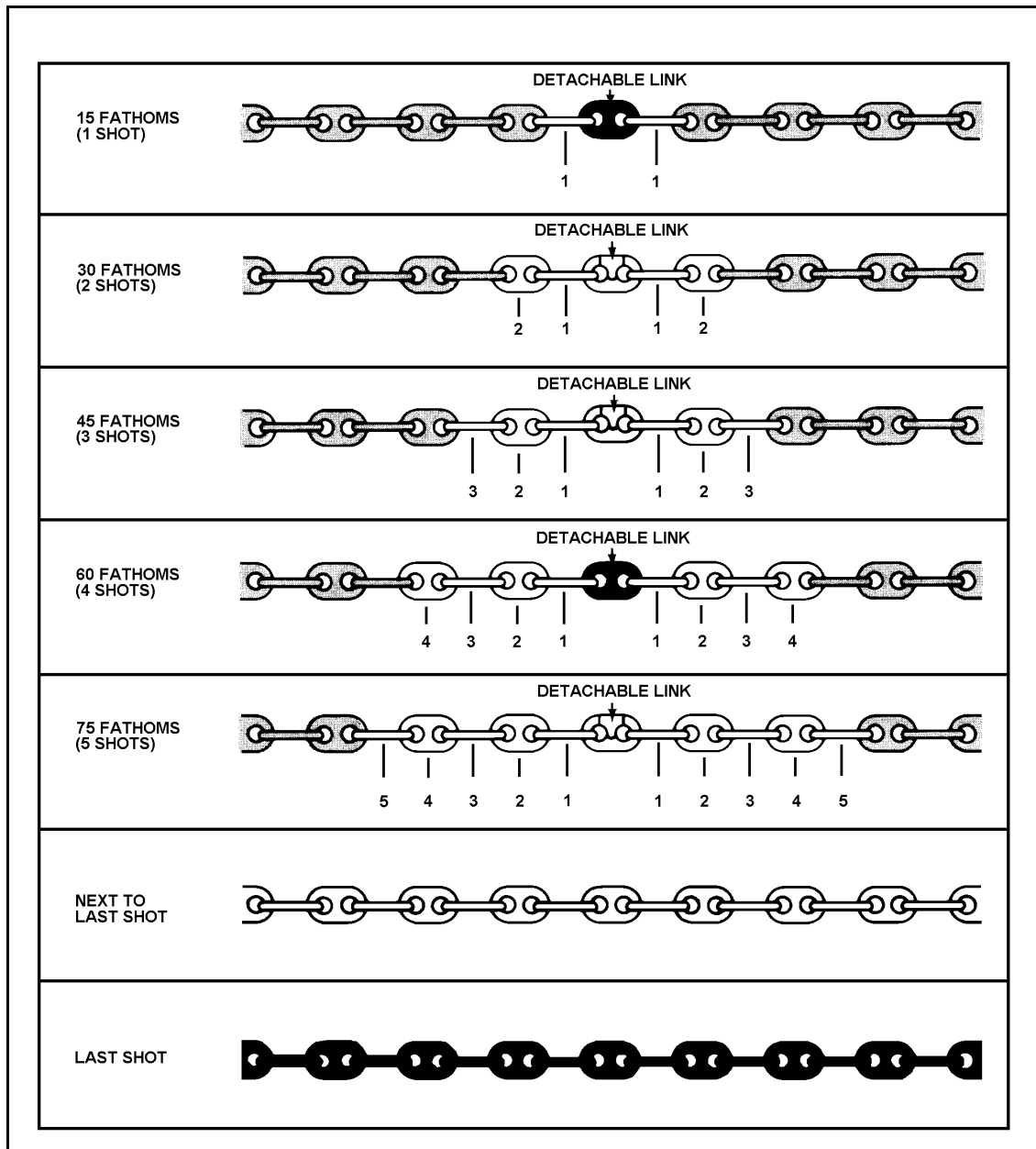

Figure 21-5. Standard Anchor Chain Markings

THE ANCHOR WINDLASS

21-15. The anchor windlass is installed on vessels primarily for handling and securing the anchor and anchor chain. Windlasses are provided with capstans or catheads, which are used for handling mooring lines when docking and undocking.

TYPES

21-16. There are two general types of windlasses installed aboard Army harbor craft. These are the horizontal shaft windlass (Figure 21-6) and the vertical shaft windlass (Figure 21-7).

Horizontal Shaft

21-17. This type of windlass is usually a self-contained unit with the windlass and windlass motor mounted on the same bedplate. It handles both the port and starboard anchors and is found aboard large vessels. Figure 21-8 shows the side view of this windlass.

Vertical Shaft

21-18. This type of windlass is found on tugs and barges. With the vertical shaft windlass, the power source is located below the deck with only the wildcat and capstan showing above the deck. The controller for the windlass is also above deck. This type of windlass can handle only one anchor.

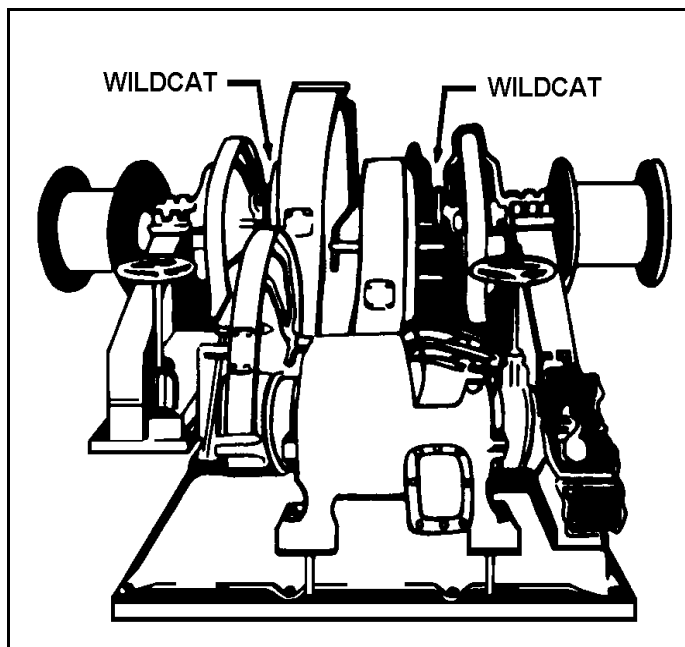

Figure 21-6. Horizontal Shaft Windlass

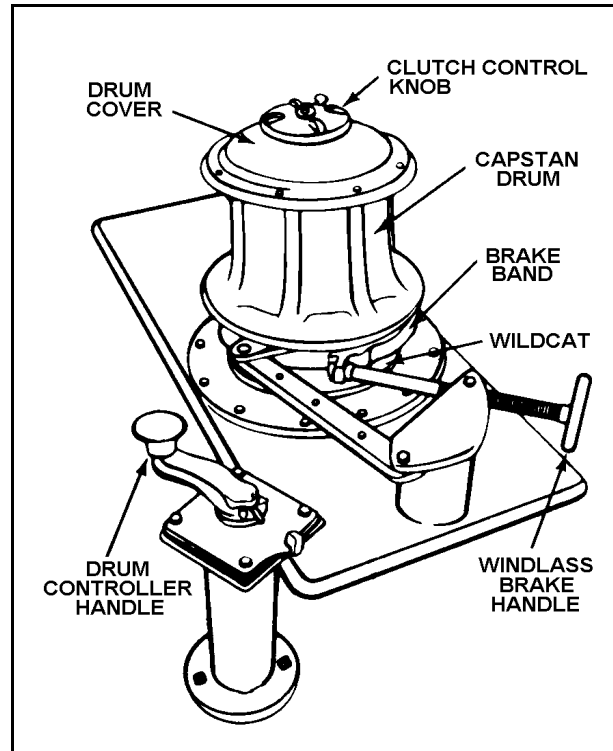

Figure 21-7. Vertical Shaft Windlass

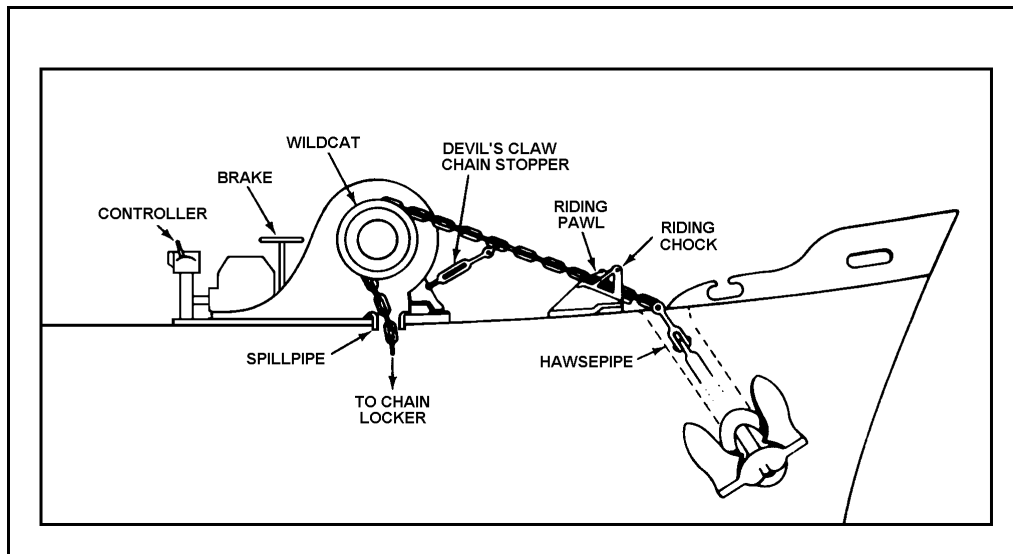

Figure 21-8. Side View of Horizontal Shaft Anchor Windlass

TERMINOLOGY

21-19. Although there is a difference in construction and appearance between the horizontal and the vertical shaft windlass, they do share a common terminology. Definitions of parts of equipment used in anchoring, starting at the anchor and working aft, are as follows:

- **Hawsepipe.** Openings in the eyes of forward part of the ship where the shank of the anchor is stowed.
- **Buckler plate.** A heavy steel plate that is “dogged down” by butterfly nuts when the vessel is at sea. The buckler plate covers the hawsepipe opening on deck and prevents water from rushing up the hawsepipe and spilling on deck.
- **Riding chock.** A metal fairlead for the anchor chain. It prevents the chain from fowling on deck and also holds the riding pawl.
- **Riding pawl.** A safety stopper, that works like a rocket on the links of the chain. It is lifted up to the “open” position when the anchor chain is run out. When heaving the chain in, the pawl is “closed” or dropped in the after side of the riding chock. The pawl bounces over the incoming chain. However, if an emergency occurs, such as the wildcat jumping out of gear, the pawl will catch on a link of the anchor chain and hold the chain and keep it from running out.
- **Chain stopper.** A turnbuckle inserted in a short section of chain with a pelican hook or a devil’s claw attached to one end and a shackle on the other end. The stopper chain is screwed at the base of the windlass. In operation, the devil’s claws are used when the vessel is setting out to sea. The claws are put on a link of the chain and the turnbuckle is set up, acting as a permanent stopper. On some ships, a pelican hook is used.
- **Wildcat.** A sprocketed wheel in the windlass with indentations for the links of the anchor chain. The wildcat, when engaged, either hauls in or pays out the anchor chain. When disengaged, the wildcat turns freely and the only control of the anchor chain is the friction brake.
- **Friction brake.** A band which bears on a flywheel. By tightening up on the band by means of the brake handle, the wildcat can be controlled.
- **Locking ring.** A device, with pigeon holes, into which a bar is placed to lock the wildcat to the hoisting gear of the engine. The locking ring is usually turned forward to disengage the wildcat and turned aft to engage it. On the capstan the wildcat is engaged or disengaged by turning the capstan barrel cover.

LETTING GO THE ANCHOR--GENERAL PROCEDURES

21-20. Certain procedures are required when preparing to let go the anchor. For this discussion, assume that the anchors are secured for sea with the spillpipes cemented in (see paragraph 21-29). This is a practice of good seamanship for ships operating at sea, where there are many days between ports or when heavy weather is expected.

WARNINGS:

- 1. ONLY CREW MEMBERS ON THE ANCHOR DETAIL WILL BE PERMITTED ON THE BOW.**
- 2. CREW MEMBERS WILL NOT STAND BETWEEN THE CAPSTAN AND THE HAWSEPIPE WHEN LETTING GO THE ANCHOR.**

Use the following procedures prior to entering port or when planning to use the anchor.

- Make sure the devil's claw assembly is taut.
- Engage the wildcat and release the brake.
- "Walk out" enough chains to break out the cement plugs in the spillpipes and free the chains.
- "Walk" the chain back to the original position.
- Clean area around the chain and anchor.
- Release the devil's claw or hooks.
- Put the riding pawls in the OPEN position.
- Make sure that the anchor is not frozen or jammed in the hawsepipe. The best way to do this is to "walk out" the anchor until it is clear of the hawsepipe.
- Having freed the anchor, set the brake tight and disengage the wildcat.
- The anchor is free.

Note: On vessels having two anchors, get both anchors ready.

OPERATING THE CAPSTAN ANCHOR WINDLASS

21-21. The Markey type VEV-16 anchor windlass (see Figure 21-9) with the single vertical capstan barrel, is the type described here. Although there are other types of vertical capstan barrel anchor windlasses in the system, their method of operation will, in most cases, be similar. The capstan barrel is keyed to the main shaft and is in continuous motion while the motor is running. The wildcat is driven off the capstan by two axial keys that may be engaged or disengaged by turning the capstan barrel cover (clutch) (see Figure 21-10). An inner drum, to which the capstan barrel cover is bolted, provides two axial cams that engage the two keys and moves them up or down as the barrel cover is turned. Indicator plates show key engagement and spring ball locks are provided to hold the shifter mechanism in either position.

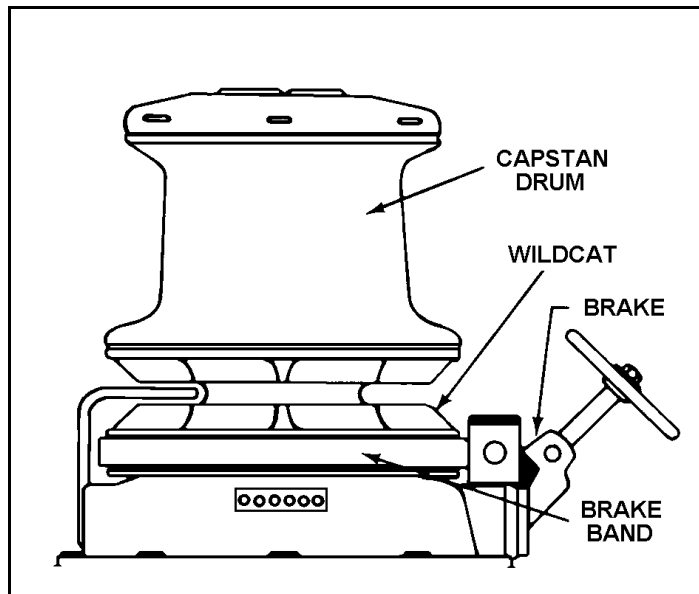

Figure 21-9. Capstan/Wildcat and Brake

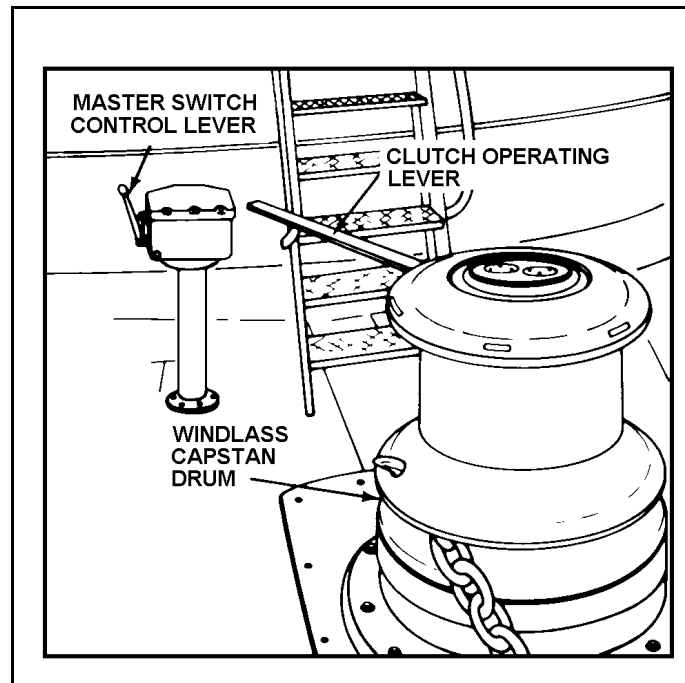

Figure 21-10. Turning the Drum Brake

DROPPING THE ANCHOR WITHOUT POWER

21-22. Use the following steps when dropping the anchor without power:

WARNING: SAFETY GOGGLES MUST BE WORN WHEN DROPPING THE ANCHOR WITHOUT POWER. THERE WILL BE A GREAT DEAL OF RUST, SPARKS, DIRT, AND DEBRIS FLYING ABOUT AS THE CHAIN RUNS OUT.

- Remove and stow the buckler plates.
- Make sure that the brake is on by fully turning the handwheel counterclockwise.
- Disengage the axial keys by turning the capstan barrel cover.
- Remove the chain stopper and open the riding pawl.
- Let go the anchor by releasing the brake (turning the handwheel clockwise). The anchor and chain will run freely when the brake is released. Use the brake to control the running speed of the chain.

WARNING: DO NOT ALLOW THE CHAIN TO RUN TOO SLOWLY. THE BRAKE, WHEN SLIPPING CONTINUOUSLY, WILL DEVELOP EXCESSIVE HEAT AND MAY BURN OUT. HOWEVER, THE CHAIN MUST NOT RUN SO FAST THAT IT WILL JUMP OUT OF THE WILDCAT.

Note: Once the anchor has hit the bottom and the strain is taken off the anchor chain, there should be a natural slowing down in the rate that the chain pays out.

- To stop lowering the anchor, turn the brake handwheel counterclockwise. This applies the brake.
- To secure, close the riding pawl and replace the chain stopper.

Notes:

1. As soon as the anchor hits bottom, during daylight hours, raise the anchor ball; during darkness turn on the anchor lights and shut off the navigation lights.
2. During daylight, after the ship is anchored, the union jack should be hoisted and flown from the jack staff. The national ensign should be shifted from the gaff to the flag staff at the stern.

RAISING THE ANCHOR

21-23. Use the following procedures to raise the anchor.

- Turn the stop switch lever of the controller to the ON position and check for power.

WARNING: WHENEVER THE CONTROLLER IS LEFT UNATTENDED, THE STOP SWITCH MUST BE PUT IN THE OFF POSITION.

- Check to see that the brake is on.
- Turn the capstan barrel cover to engage the two axial keys. This will put the wildcat in motion when the controller is operated.
- Put the controller handle in the hoist position and take a strain on the anchor chain, then stop.
- Drop the riding pawl.
- Release the chain stopper.
- Open the brake.
- Put the controller handle in the hoist position and raise the anchor. You will usually feel a “surge” or release of strain on the anchor chain when the anchor breaks free of the bottom.

Note: As the anchor chain is coming in, crew members should be stationed at the hawsepipe with a fire hose. The chain should be thoroughly washed down and freed of all mud, silt, and debris.

- House the anchor.
- Put on the brake.
- Replace the chain stopper.
- Disengage the axial keys by turning the capstan barrel cover.

Notes:

1. As soon as the anchor breaks free of the bottom, during daylight hours, drop the anchor ball. During darkness, switch off the anchor lights and turn on normal navigation lights.
2. Once the "anchor ball" is lowered, the ship is underway. The union jack is lowered and the national ensign is transferred to the gaff.

OPERATING THE HORIZONTAL ANCHOR WINDLASS

21-24. Anchor windlasses and their accompanying equipment vary in size and shape depending on the type and size ship on which they are used. However, the procedure for releasing the anchor remains the same.

LETTING GO THE ANCHOR

21-25. To let go the anchor do the following:

- Inspect the anchor windlass, anchor chain, hawsepipes, and anchor to see that they are free and clear for letting go the anchor.
- Make sure that the brake is set tight (Figure 21-11, page 21-16).
- Disengage the wildcat (Figure 21-12, page 21-16).
- Lift the locking ring key on the locking ring (Figure 21-13, page 21-16).
- Insert the anchor bar into the pigeonhole on the locking ring (Figure 21-14, page 21-16). The locking ring is then turned forward to disengage the wildcat.
- Wildcat is disengaged (Figure 21-15, page 21-17).
- Remove the chain stopper. The turnbuckle is secured at the base of the windlass.

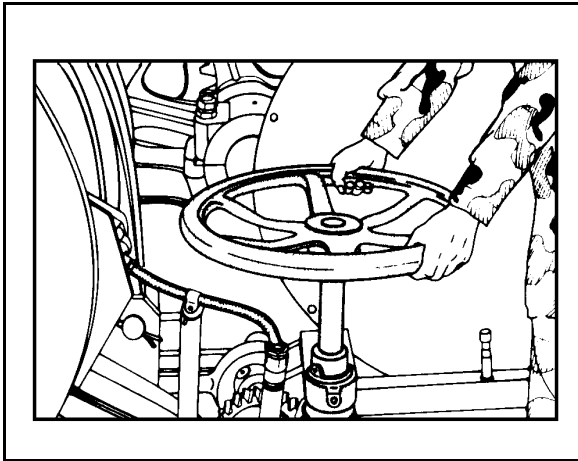

Figure 21-11. Setting Up Brake

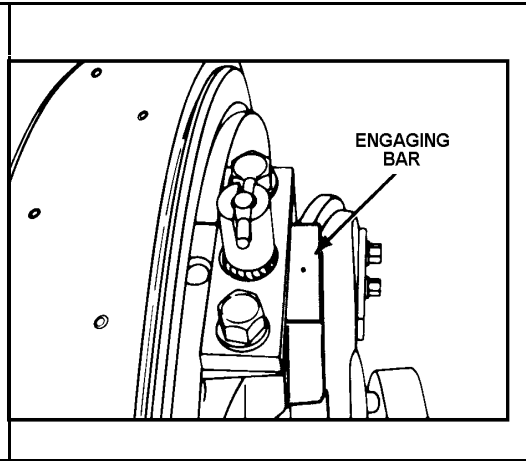

Figure 21-12. Wildcat Engaged

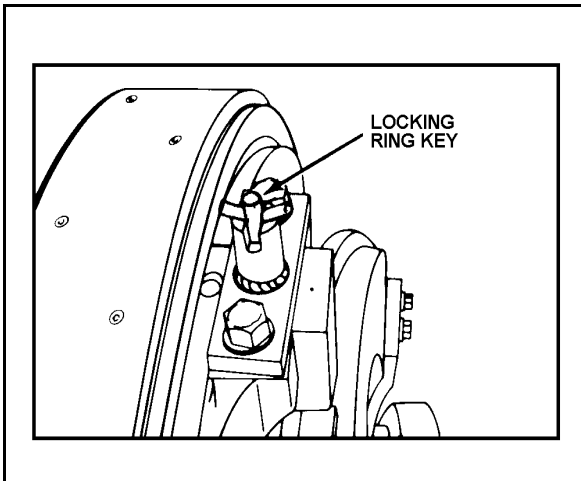

Figure 21-13. Lifting Locking Ring

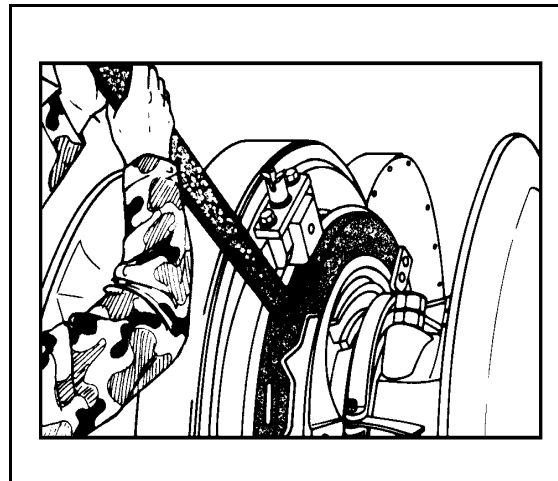

Figure 21-14. Inserting Anchor Bar

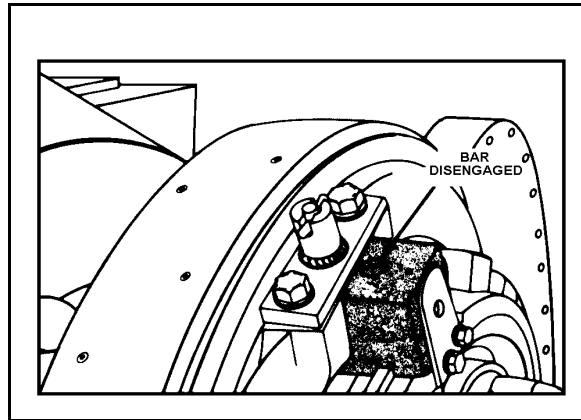

Figure 21-15. Wildcat Disengaged

21-26. The devil's claw is put on a link of the anchor chain, and the turnbuckle is set up, acting as a permanent stopper.

- Slack off anchor chain stopper (Figure 21-16).
- Take off the devil's claw (Figure 21-17, page 21-18).
- Lift open the riding pawl (Figure 21-18, page 21-18).
- On command from the bridge, let go the anchor by releasing the brake. Wear your safety goggles and keep your head turned to the side to protect your eyes from flying rust, sparks, and dirt from the anchor chain. Usually one can sense when the anchor hits the bottom--there is a noticeable slackening in speed of the chain paying out.
- Once the chain has hit bottom and slowed up in paying out, tighten the brake to where you can control the paying out of the chain.

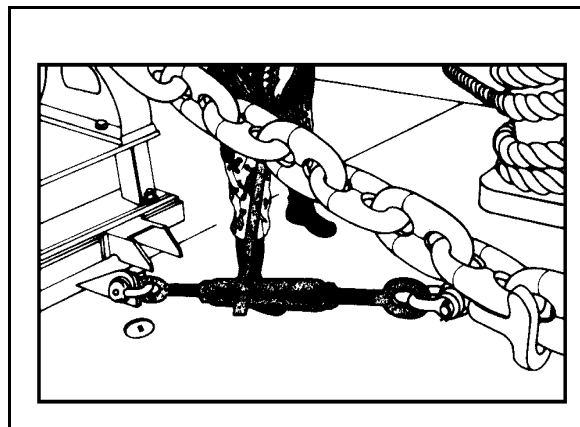

Figure 21-16. Slacking Off Chain Stopper

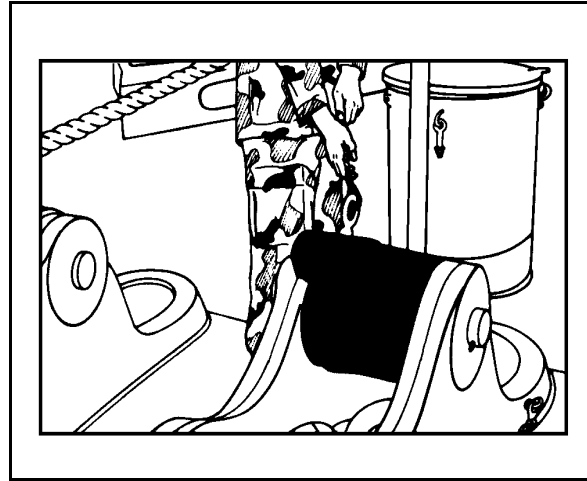
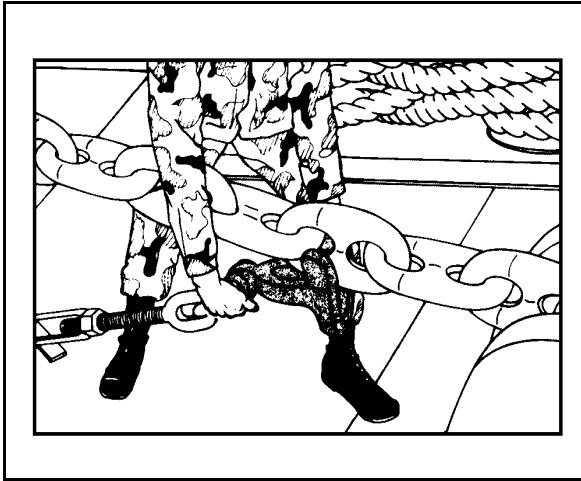

Figure 21-17. Removing the Devil's Claw

Figure 21-18. Opening Riding Pawl

Note: During daylight hours, as soon as the anchor hits the bottom, raise the anchor ball. Next, raise the union jack and shift the national ensign from the gaff to the flag staff. During hours of darkness or restricted visibility, as soon as the anchor hits the bottom, turn on the anchor lights and shut off the navigation lights.

- Secure the brake. Use the anchor bar or a "valve wrench" to set up on the brake (Figure 21-19).
- Replace the stopper. After the brake has been set up, then hook up the devil's claw and secure the stopper (Figure 21-20). This will aid in holding the anchor and take some of the strain from the brake.
- Close the riding pawl (Figure 21-21).

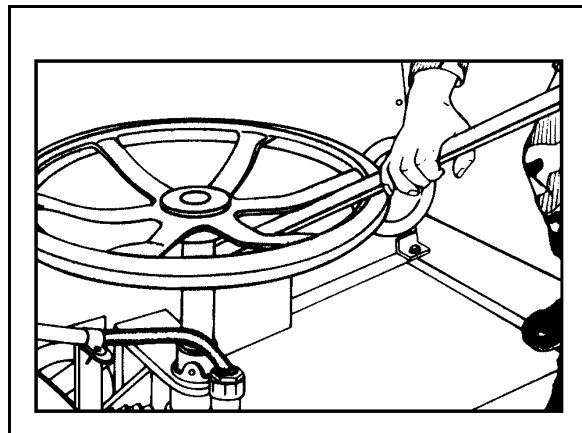

Figure 21-19. Setting Brake

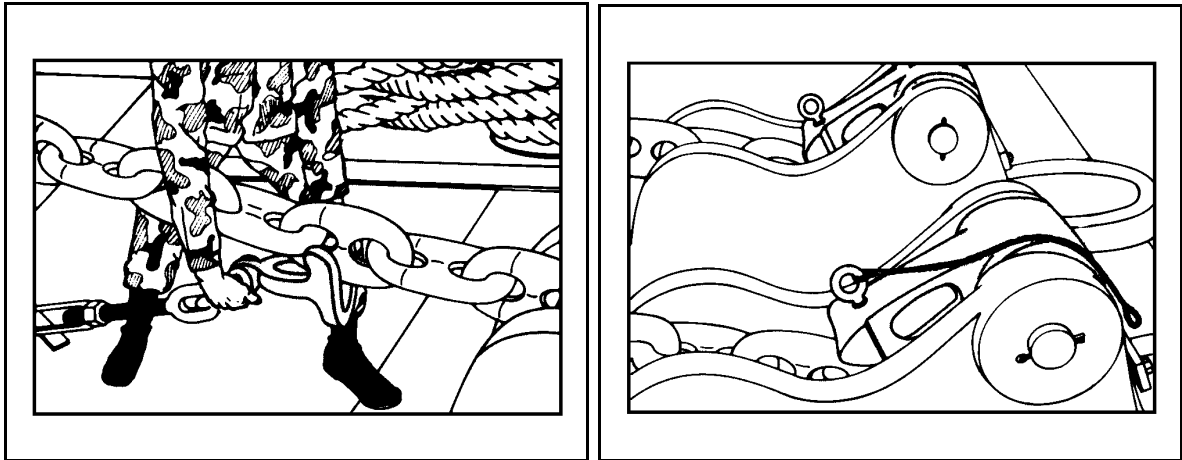

Figure 21-20. Securing Devil's Claw
Figure 21-21. Closing Riding Pawl

RAISING THE ANCHOR

21-27. Use the following procedures when raising the anchor.

- Inspect the anchor windlass, chain, hawsepipe, and anchor to see that they are free and clear.
- Turn on the power switch and then push the control handle forward to the lower position (Figure 21-22, page 21-20). Put it in this position just long enough to hear the power turn on, then bring the control handle back to the stop position.
- Make sure that the brake is secured.
- Engage the wildcat.
- Lift locking ring key on locking ring (Figure 21-23, page 21-20).
- Using the anchor bar, turn the locking ring to engage the wildcat (Figure 21-24, page 21-20). Figure 21-25, page 21-20, shows the wildcat engaged.
- Remove the anchor chain stopper.
- Turn on the power and, using the windlass control, pull back on the handle. Take just enough strain to where you hear the engaging bar hit the spoke of the windlass, then stop.
- Release the brake. Slack off on the brake until it is free.
- Raise anchor on anchor windlass control.
- House the anchor.
- Put on the brake.
- Replace the chain stopper.
- Disengage the windlass.

Notes:

1. If the locking ring does not turn freely, go back to the control lever, push it forward and move locking ring forward about 1 inch. This will take the pressure off the engaging bar.
2. Crew members should be stationed at the hawsepipe with a fire hose. The chain should be thoroughly washed down and freed of all mud, silt, and debris as it is hauled in.
3. When the anchor breaks free of the bottom, during daylight hours, lower the anchor ball and the union jack; shift the national ensign back to the gaff. During hours of darkness, shut off anchor lights and turn on navigation lights.

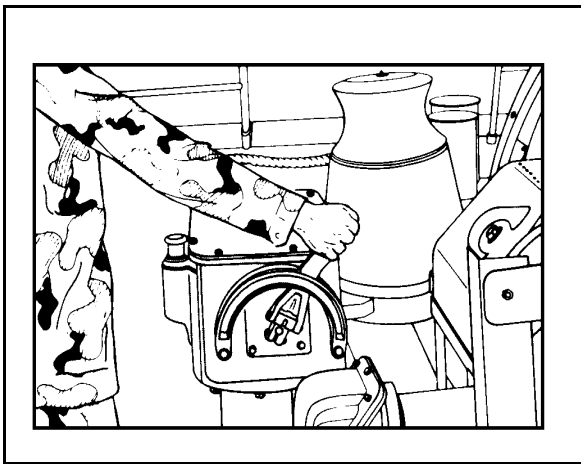

Figure 21-22. Checking Controller

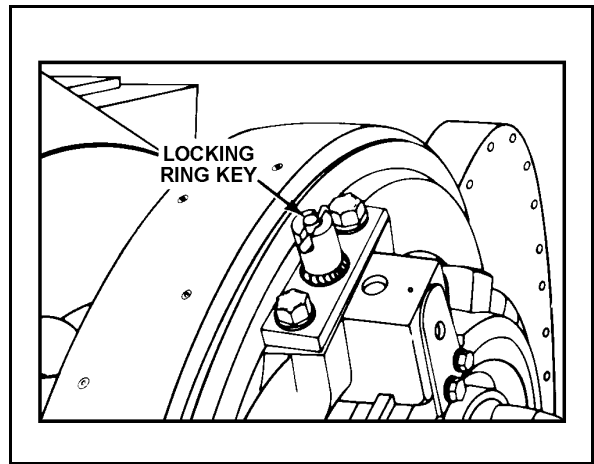

Figure 21-23. Lift Locking Ring Key

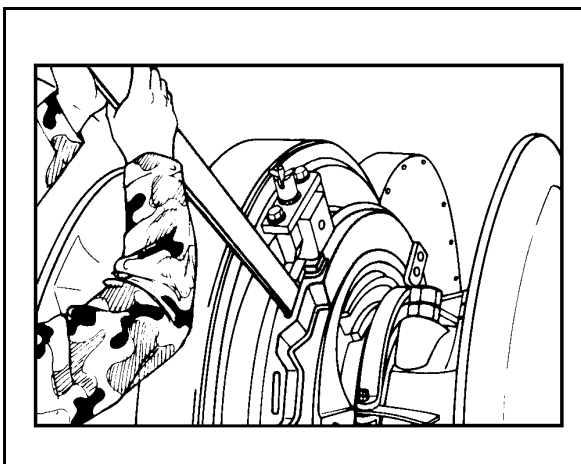

Figure 21-24. Engaging Wildcat

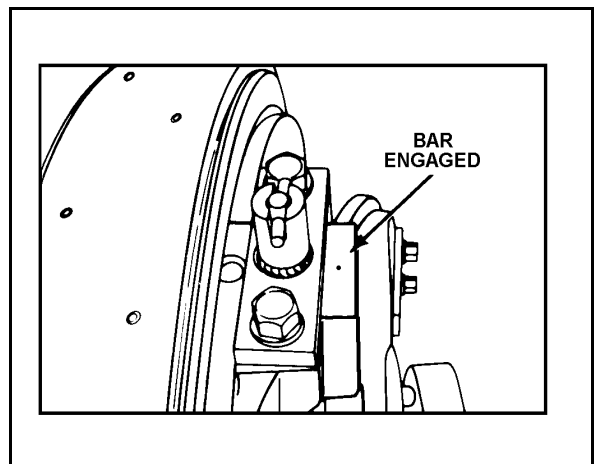

Figure 21-25. Wildcat Engaged

SEQUENCE OF WEIGHING ANCHOR

21-28. Figure 21-26, pages 21-22 and 21-23, shows the seven stages of weighing anchor.

SECURING THE ANCHOR FOR SEA

21-29. When securing the anchor for sea; place small pieces of wood between the chain links, about 8 to 10 inches below the top of the spillpipe. Then on top of this, rags are stuffed. Mix up a pail of cement (50 percent cement, 50 percent sand) for each spillpipe. Pour it in on top.

21-30. It should fill right to the top of the spillpipe. The layer of cement should be at least 1-inch thick. To help it set up and dry, you can throw a handful of dry cement on top of the wet cement, this will absorb the excess water. Then cover the spillpipe with an old piece of canvas. This will help protect the cement plug and give it a chance to dry. Figure 21-27, page 21-24, shows a side view of a cemented spillpipe.

MAINTENANCE

21-31. The external maintenance of the anchor windlass and the periodic maintenance and checks of the anchor chain are the responsibility of the deck department.

MAINTENANCE OF THE WINDLASS

21-32. Maintenance and adjustment of equipment should be continued during periods when it is not in use to prevent deterioration and to provide dependable operation. Inspect windlass weekly and operate as necessary to ensure that equipment is in proper condition.

21-33. Each wildcat is equipped with an externally contracting brake flat band operated by a handwheel. This brake can be used to hold the anchor and chain and to control the rate of descent. Inspect this brake regularly for wear, maladjustment, and defective parts. Consult the applicable windlass technical manual for detailed instructions for maintenance and adjustment of the brake. Failure of the wildcat brake can result in loss of the anchor and chain.

21-34. Lubrication instructions are provided in the applicable TM lubrication chart. These instructions should be followed as to grades of lubricant, frequency of application, and points of application.

21-35. If the windlass is not used frequently, it should be lubricated before each operation in accordance with the applicable TM. Rotation of the windlass by power during lubrication will distribute the lubricant evenly. The locking mechanism can be disengaged and the chain held by engaging the wildcat brake.

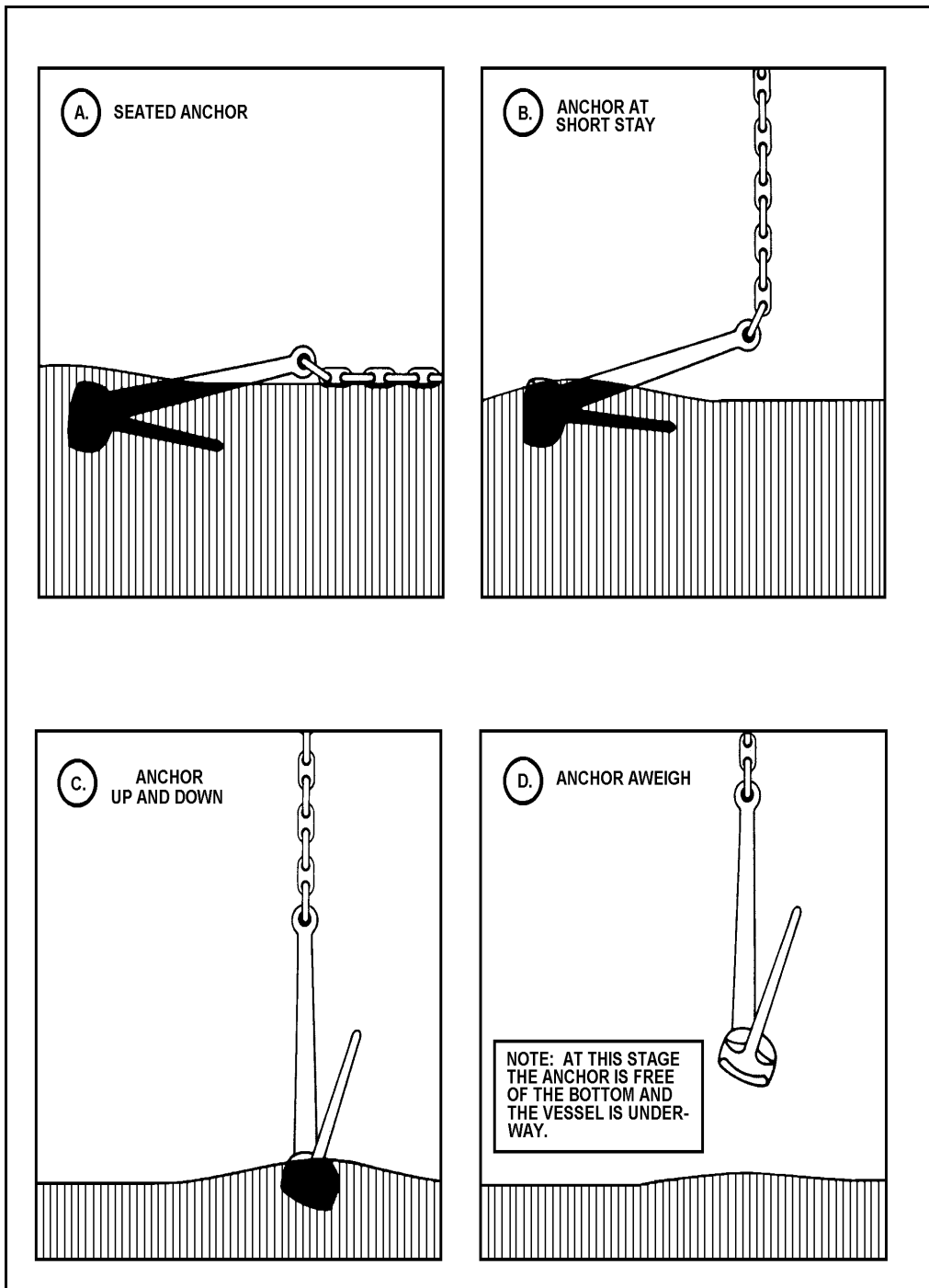

Figure 21-26. Sequence of Weighing Anchor

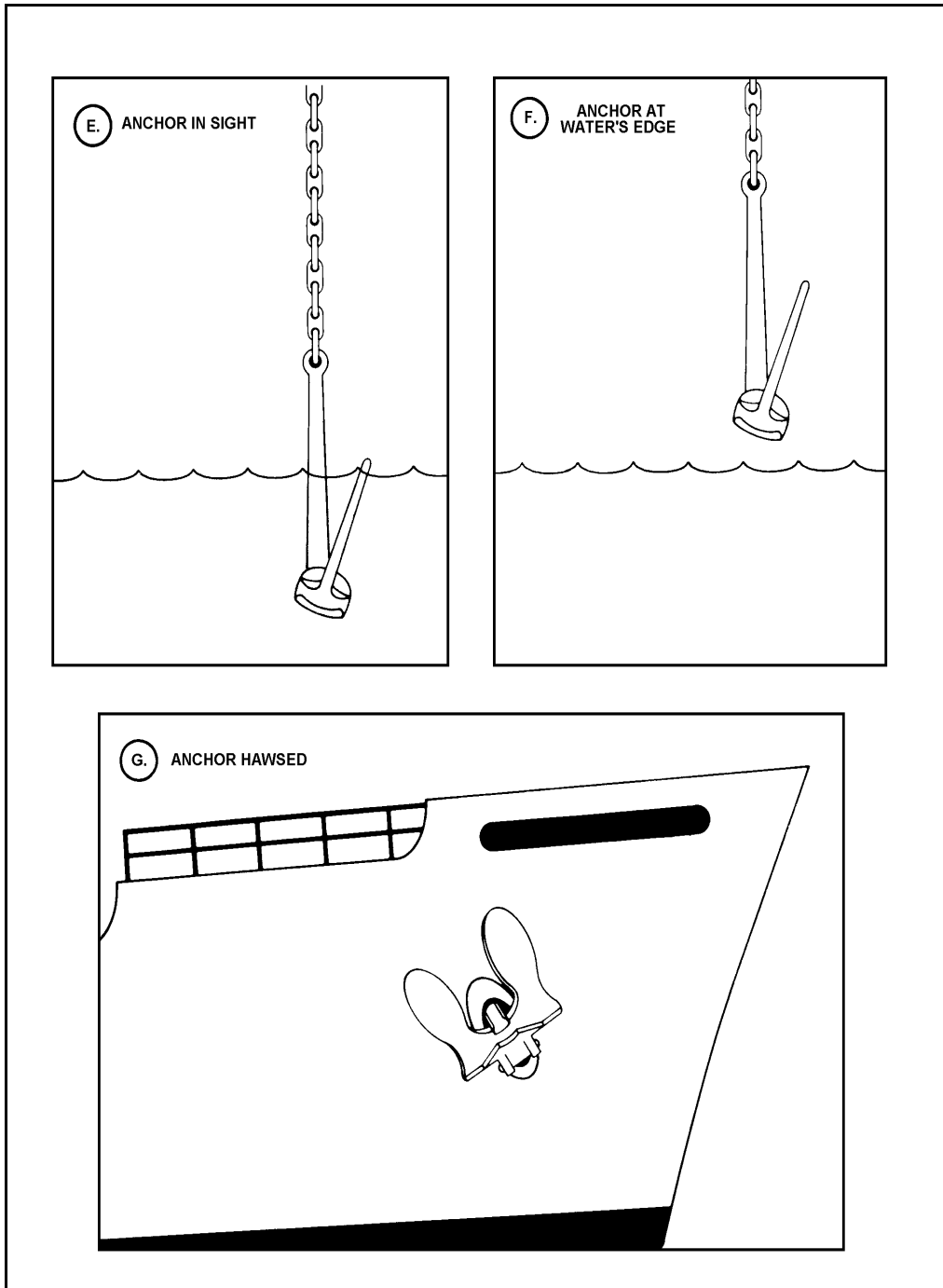

Figure 21-26. Sequence of Weighing Anchor (continued)

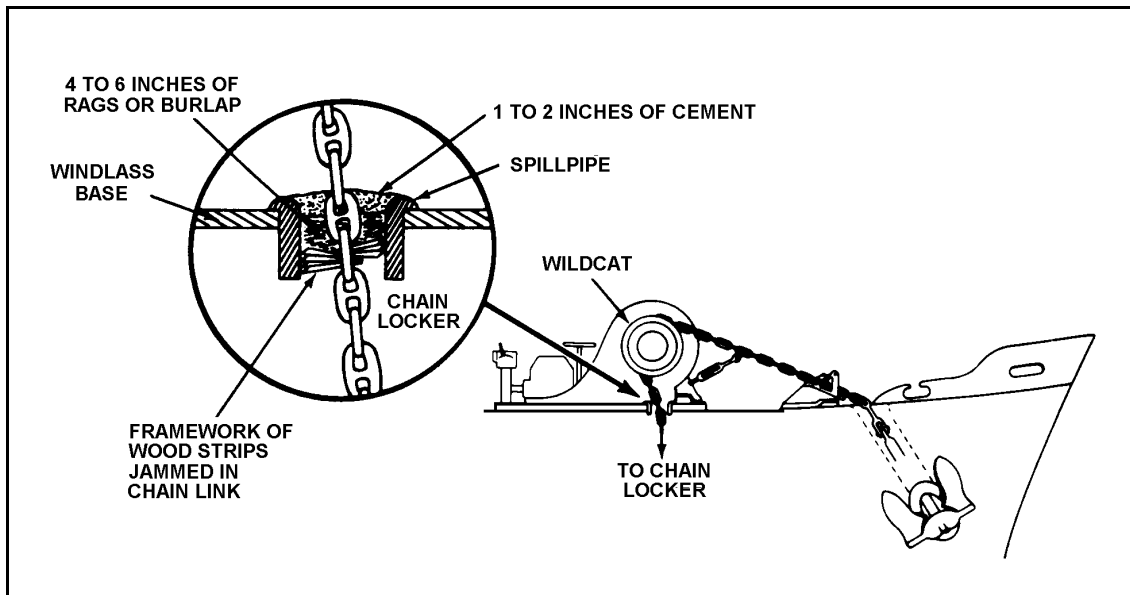

Figure 21-27. Side View of Cemented Spillpipe

21-36. After using the windlass, lubricate the equipment to prevent rusting and freezing of adjacent parts and to protect finished surfaces from corrosion.

21-37. Check the mounting frame to ensure that nuts and holddown bolts are tight.

21-38. Chip, scrape, preserve, and paint the frame, catheads, brake bands, and external parts of the brake band. Keep them free of rust.

MAINTENANCE OF THE ANCHOR CHAIN

21-39. Only minor maintenance can be performed on anchor chains. High-strength, welded chain and appendages can only be overhauled and heat-treated by shipyards meeting the requirements of the DOD.

Maintaining Chain Identification Marks

21-40. Each shot of anchor chain usually bears a serial number that is stamped, cut, or cast on the inner side of the end links at the time of manufacture. In the case of cast steel chain, this number is preceded by the letters C.S. If an end link is lost or removed from a shot, this identification number should be cut or stamped on the side of the new end link of the altered shot. The studs of forged-iron and forged-steel, fire-welded links have the wire diameter of the links imposed on the reverse side, with the opposite side indicated in raised letters. Cast steel and some types of high-strength, welded steel chain have these markings on the studs of alternate links only.

Restrictions as to Use of Chain Appendages

21-41. During makeup or repair, anchor chain appendages should be restricted to the purposes for which they are intended. The intended uses are obvious, but particular attention should be given to the uses of the detachable link.

Periodic Maintenance

21-42. Semiannually, all anchor chains of sizes up to and including 1 1/2 inches should be arranged on deck and examined throughout their length. If necessary, they should be scaled and cleaned of rust and foreign matter. Detachable links should be disassembled, examined for excessive wear or corrosion, and replaced as necessary. When the stock of detachable links is exhausted, new high-strength detachable links will replace the standard detachable links in sizes from 3/4 inch to 1 3/4 inches inclusive. These new links will have proof loads equal to the breaking load of the standard detachable links. Before reassembly, coat the new links with white lead. The detachable link, located in the outboard swivel shot, is fitted with a corrosion-resisting steel locking wire, which serves to hold the taper pin in position. Disassembly of this link requires the removal and probable destruction of the locking wire. A replacement wire of the same type should be carefully examined, put in order, and, if needed, coated with red-lead primer, Military Specification MIL-P-17545; zinc-chromate primer, Federal Specification TT-P-645; or Military Specification MIL-P-8585. This should be followed by one coat of black enamel, Military Specification MIL-P-15146. When facilities permit, the chain links should be preheated prior to both the primer and final coat of painting. A temperature of 250° F (121° C) is recommended, but a lower temperature of 150° F (66° C) will decrease the drying time. In cold weather, apply some heat to counteract the natural thickening of paint. This can be accomplished by using an immersion-type electric heater or a steam coil. When left standing for a considerable period, the turpentine substitute can evaporate to such an extent that it will cause thickening of the paint. The addition of solvent will remedy such a condition.

Note: Vessels which receive anchor chains that have been coated with either red-lead primer or zinc-chromate primer and black enamel or black-asphalt varnish should have this coating left intact and covered with one coat of black enamel, Military Specification MIL-P-15146.

Replacement of Worn Chain

21-43. Replace any part of the chain that has corroded or worn so that the mean diameter is reduced to 90 percent of its normal diameter. However, replace only if the diameters of the remaining links allow continued use. If it appears uneconomical to replace worn parts, the chain should be surveyed. If replacements are made, the new links, shackles, or parts should be heat-treated, proof-tested, and, in the case of wrought iron, heat-treated again. In each case a complete report should be made containing the following information:

- Material composition of the chain.
- Shot number.
- Length of each shot.
- Nature of work actually performed on the chain.
- Date of such work.
- Cost.

This report should reference the file number of the correspondence authorizing the work involved. This report should also include disposition of the chain after the heat treatment.